

Paragon²⁰[®]

a  ZIMMER BIOMET company

SURGICAL TECHNIQUE GUIDE

Phantom[®] Hindfoot Curved Nail System





PHANTOM[®]
HINDFOOT CURVED
NAIL SYSTEM

CONTENTS:

SECTION 1	PHANTOM® HINDFOOT CURVED NAIL SYSTEM OVERVIEW
	IMPLANT OFFERING 3-4
	FEATURED INSTRUMENTATION 5-9
SECTION 2	SURGICAL TECHNIQUE - TTC FUSION WITH PHANTOM® HINDFOOT CURVED NAIL
	INCISION & TEMPORARY FIXATION 10
	IMPLANT SIZING 11
	TEMPLATE PLACEMENT 12-17
SECTION 3	REAMING OUTRIGGER
	ASSEMBLY 18-20
	ALIGNMENT 21-22
SECTION 4	IMPLANT REAMING
	ENTRY REAMING 23-26
	FINAL REAMING 27-29
SECTION 5	NAIL ASSEMBLY AND PLACEMENT
	ASSEMBLY 30-31
	NAIL PLACEMENT 32
	LATERAL TIBIA PEGS INSERTION 33-36
	LATERAL CALCANEAL PEG INSERTION 37-38
	INTERNAL COMPRESSION 39
	POSTERIOR CALCANEAL PEG INSERTION 40-41
	END CAP PLACEMENT 42-43
	CLOSURE 43
SECTION 5	IMPLANT REMOVAL
	IMPLANT REMOVAL 44
SECTION 7	CADDY AND SAFETY INFORMATION
	CADDY CONTENTS 45-46
	CADDY CONTENTS 47-48
	INDICATIONS, CONTRAINDICATIONS, WARNINGS 49

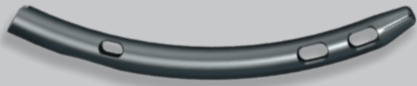
IMPLANT OFFERING:





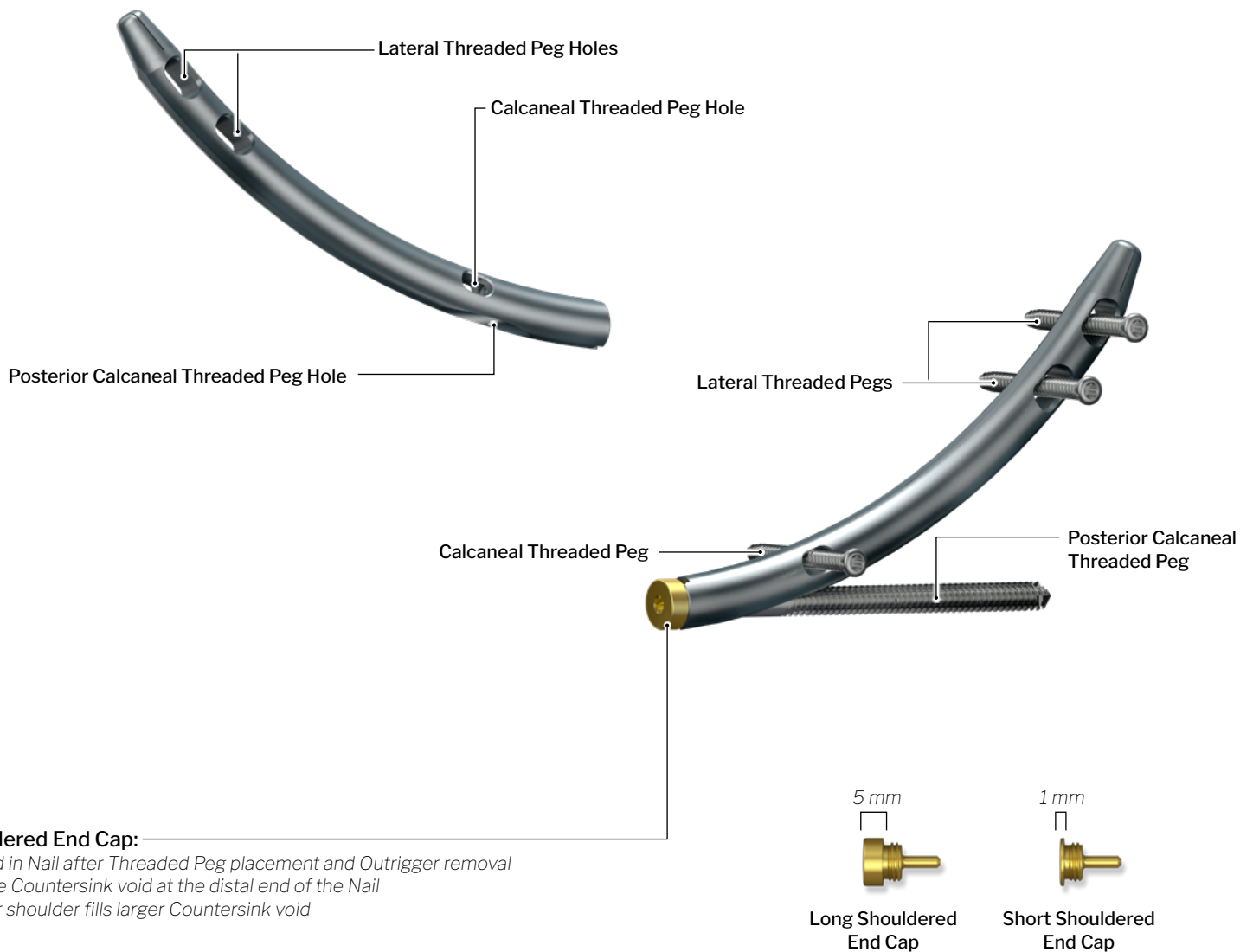







		Curved Nail Length Options			
		120 mm	140 mm	160 mm	180 mm
Curved Nail Diameter Options:	 Ø12.5 mm	●	●	●	●
	 Ø14.0 mm	●	●	●	●

CURVED NAIL FEATURES:



System Overview - Phantom® Curved Nail System

FEATURED IMPLANTS & INSTRUMENTATION:

	Lateral Tibia & Calcaneal Threaded Peg	Posterior Calcaneal Threaded Peg
		
Diameter:	Ø5.0 mm	Ø7.0 mm
Length:	20 mm - 70 mm in 2 mm increments	45 mm - 120 mm in 5 mm increments
Instrument Color:		
Driver:	TX-20 Driver (90 mm and 160 mm length) 	TX-25 Driver (90 mm and 210 mm length) 
Drill:	Ø3.8 x 250 mm -Solid 	Ø4.6 x 340 mm -Solid 
Drill Guide:	Outrigger Lateral Drill Guide 	Outrigger Posterior Drill Guide 
Peg Guide:	Outrigger Lateral Peg Guide 	Outrigger Posterior Peg Guide 

 Ø3.0 X 160 mm Guide Drill Pin  Ø2.7 X 20 mm Tibial Sphere Pin

 Ø2.3 x 230 mm Smooth, Single-Ended Trocar Tip K-wire

 Solid Depth Gauge

 3 mm x 224 mm Solid Hex Driver

 8.5mm Hex Bolt Driver Attachment

 3/16" Jacobs Adaptor

 1/4" Square to Jacobs Adapter

 Torque Limiting Adapter

FEATURED INSTRUMENTATION:



Angel Wing Frame



Angel Wing Threaded Rod



Implant Sizer / Reaming Template Assembly



Strut Support Offset Bar



Attachment Handle



Grenade Pin



Offset Bar Knob



K-wire Cartridge



Reamer Cartridge



Reaming Outrigger Assembly

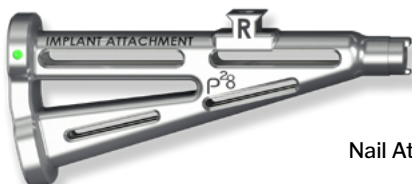

Nail Attachment Outrigger

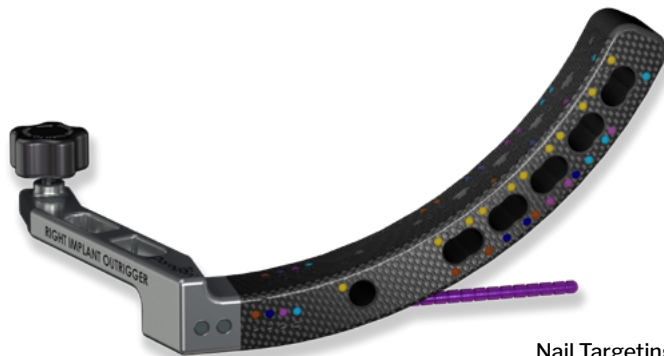

Nail Targeting Outrigger
-Available in Left and Right side



Outrigger Mounting Bolt

System Overview - Phantom® Curved Nail System

FEATURED INSTRUMENTATION:

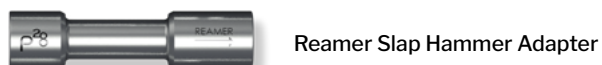
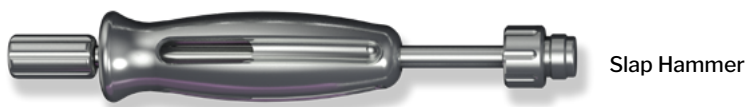
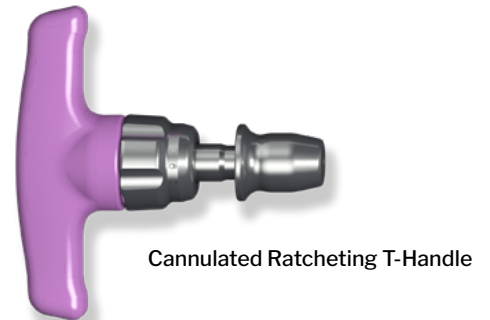
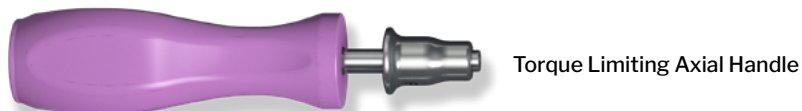
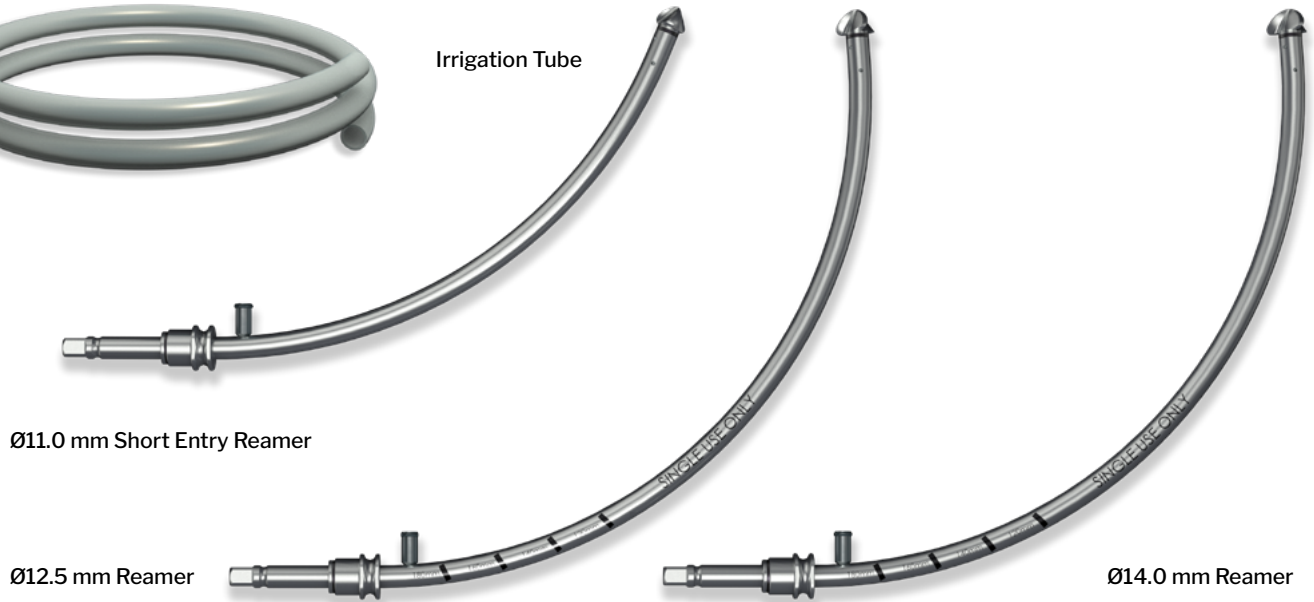

JOINT PREPARATION INSTRUMENTATION:



Curved Bone Fenestration Chisel



Ø6.0 Oval Burr



Straight Bone Fenestration Chisel



Ø6.0 Barrel Burr



Bone Fenestration Perforator



Screw Forceps



Angled 20° 7 mm Curette



Curved 7 mm Curette



Straight 7 mm Ring Curette



Angled 20° 7 mm Ring Curette



Curved 3 mm Osteotome



Curved 6 mm Osteotome



Curved 12 mm Osteotome



Straight 6 mm Osteotome



Straight 12 mm Osteotome



Cartilage Removal Tool

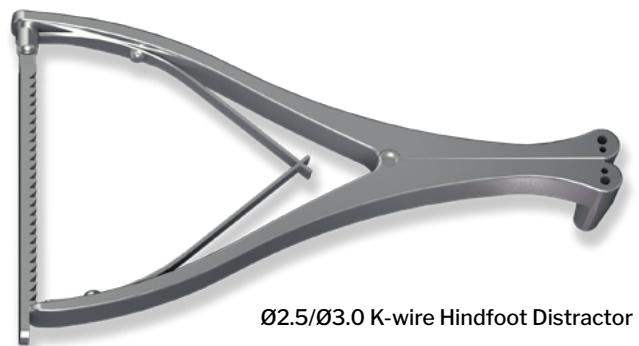

Ø2.5/Ø3.0 K-wire Hindfoot Distractor

FEATURED INSTRUMENTATION - REAMING TEMPLATE FEATURES:

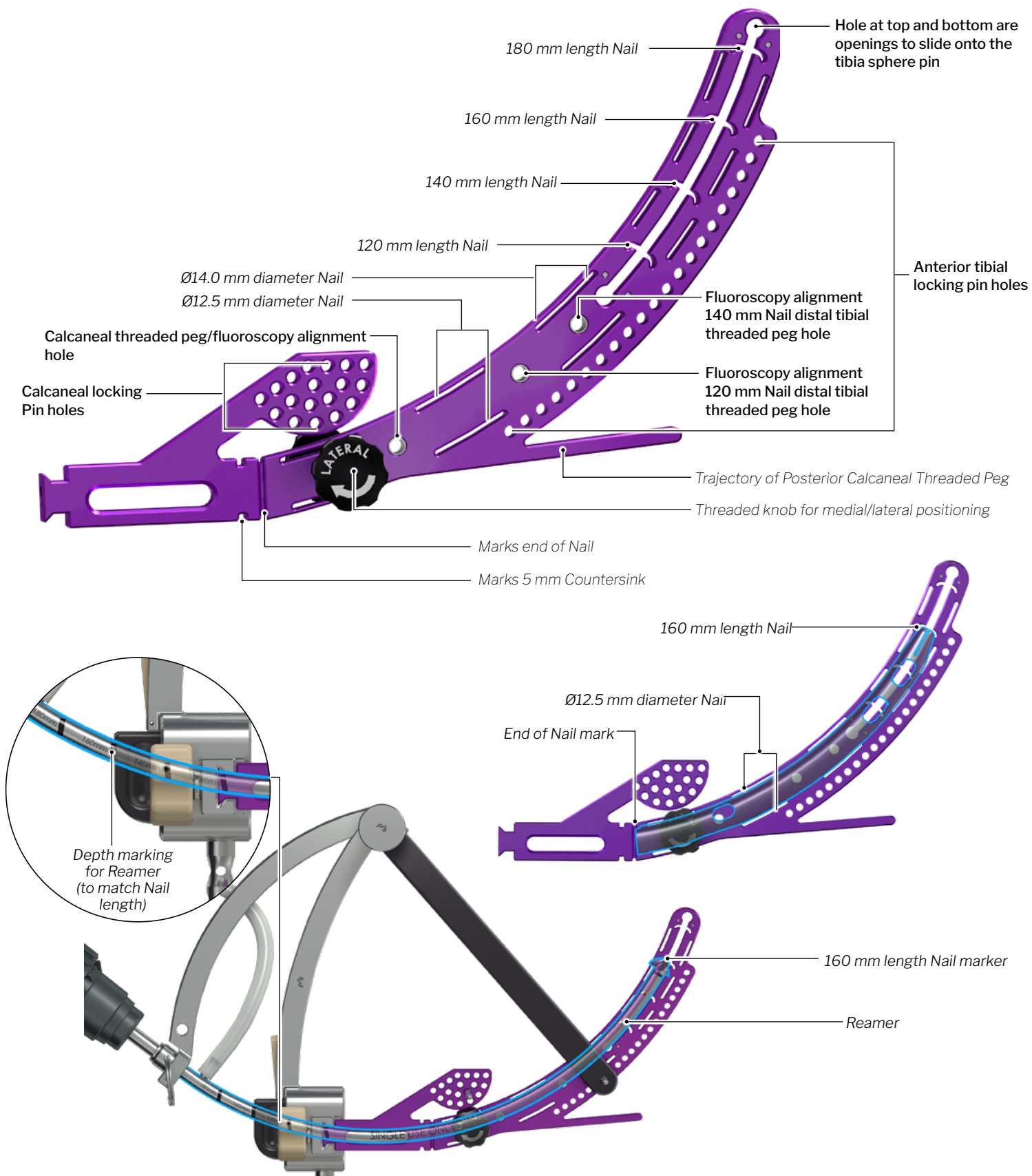

INCISION:

Position the patient in a lateral decubitus position. Make an incision over the posterior half of the fibula beginning approximately 10 cm proximal to the tip of the fibula extending distally and curving to the sinus tarsi.

Prepare the tibiotalar joint and the anterior, middle, and posterior facets of the subtalar joint for arthrodesis according to the surgeon's preferred technique using the provided joint preparation instrumentation.



NOTE: Surgical irrigation is necessary for successful completion of this operation.



NOTE: Distal fibular takedown can be performed for additional clearance according to surgeon preference.

**TIBIOTALAR AND SUBTALAR JOINT POSITIONING AND TEMPORARY FIXATION:**

Ø2.3 x 230 mm Smooth, Single-Ended Trocar Tip K-wire

Align the tibiotalar and subtalar joint to the appropriate position per surgeon discretion. Place a pair of Ø2.3 K-wires from the plantar calcaneus through the talus and into the anterior medial tibia. Confirm the Wires are placed outside the intended nail path under fluoroscopy. If necessary, K-wires can be placed in the path of the intended Nail to secure initial position and then additional wires can be placed outside of the nail path and the K-wires in the path can be removed.

If performing a TC fusion, it is recommended to have at least three temporary fixation K-wires.



OPTION: An oblique Wire from the anterior tibia into the calcaneus can be placed for additional rotational stability.

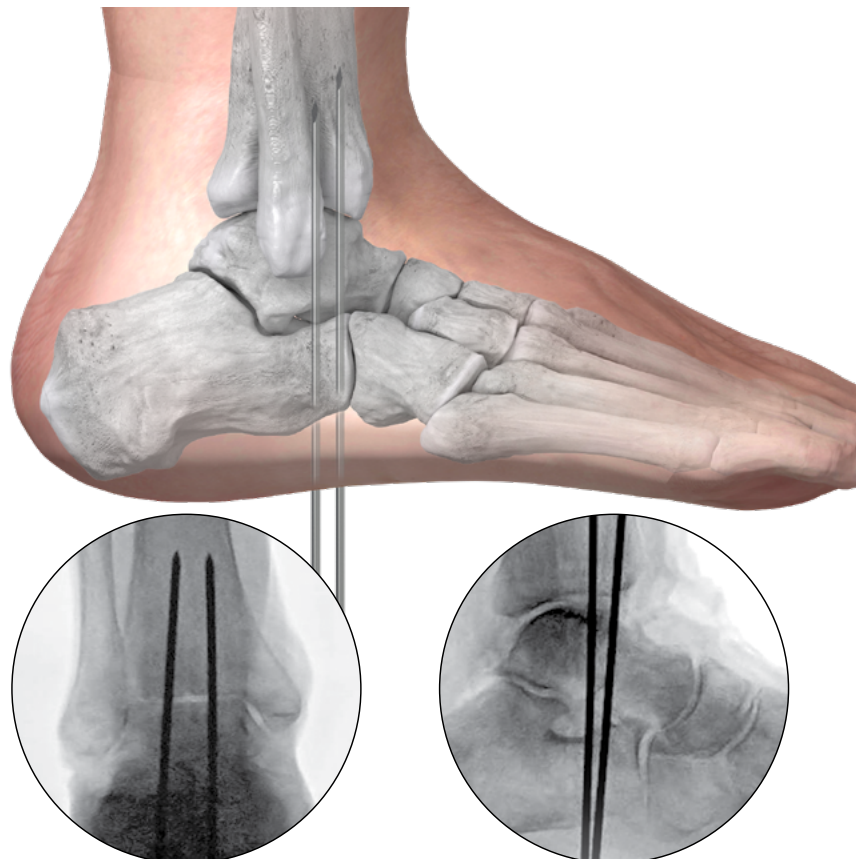

IMPLANT SIZING - NAIL LENGTH DETERMINATION:

Thread the Attachment Handle into the distal end of the Reaming Template. Ensure the Threaded Knob is centered in the Template. Place the Reaming Template over the lateral side of the leg and position the Threaded Knob approximately one to two cm distal to the lateral malleolus. Ensure a proper lateral view of the leg is seen under fluoroscopy using the Fluoro Alignment Hole. It should form a perfect circle when appropriately aligned. The Fluoro Alignment Hole should be fully in view to confirm the proper rotation of the Reaming Template.

Implant Sizer / Reaming Template Assembly

Attachment Handle

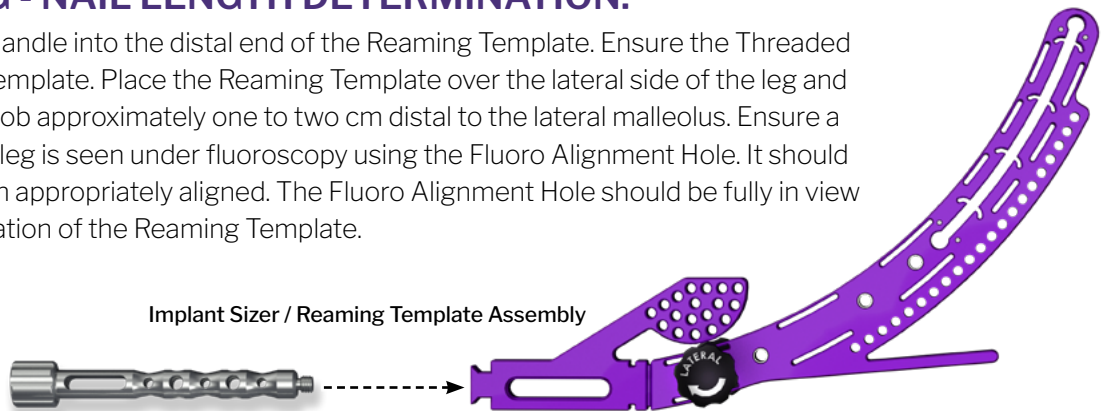

180 mm length Nail

160 mm length Nail

140 mm length Nail

120 mm length Nail

Fluoro alignment hole

Threaded Knob

5 mm countersink

Distal end of Nail

Slots for Nail diameter needed:

Ø12.5 mm

Ø14.0 mm

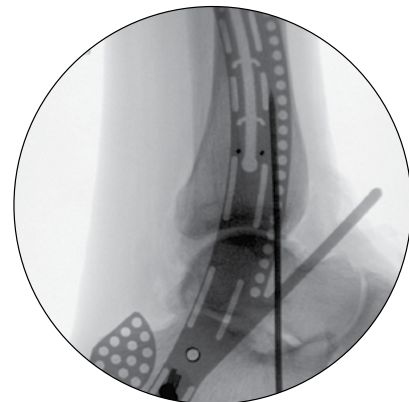

USE THE REAMING TEMPLATE TO DETERMINE:

- ✓ Fluoroscopy alignment holes forms perfect circle (true lateral)
- ✓ Nail crosses both ankle and subtalar joints
- ✓ Nail centered in tibia (not exiting anteriorly)
- ✓ Nail termination point 5mm countersunk in calcaneus
- ✓ Tibial and Calcaneal Wire holes allow bone purchase

TEMPLATE PLACEMENT:

After determining proper entry point, Nail length and path, mark the termination point of the Nail at the appropriate length notch with a surgical marker and remove the Reaming Template.

 Ø2.7 X 20 mm Tibial Sphere Pin

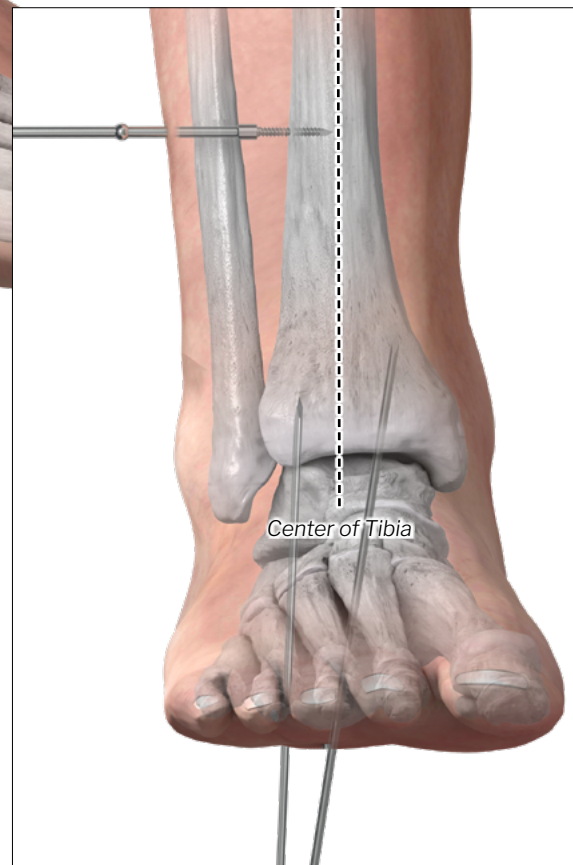

Make a stab incision at the marked location and dissect down to bone. Place a Tibial Sphere Pin in the posterior third of the tibia or just anterior to the anterior border of the fibula at the marked Nail termination point. The tip of the Pin will be the termination point of the Nail. Begin by placing the tip of the Pin centered in the tibia.

**TEMPLATE FLUOROSCOPY CHECKLIST:**

- ✓ Lateral View: Check Nail path, joint crossing, appropriate countersink
- ✓ AP view: Confirm center of joint, no medial/lateral deviation
- ✓ Calc-axial: Verify entry point, no medial/lateral bias

TEMPLATE PLACEMENT - ANKLE JOINT ALIGNMENT:

Slide the Reaming Template over the sphere Pin using the hole at the top or bottom of the Template and slide it to the appropriate length for the Nail to be used. Position the Threaded Knob approximately 1-2 cm distal to the lateral malleolus to start.

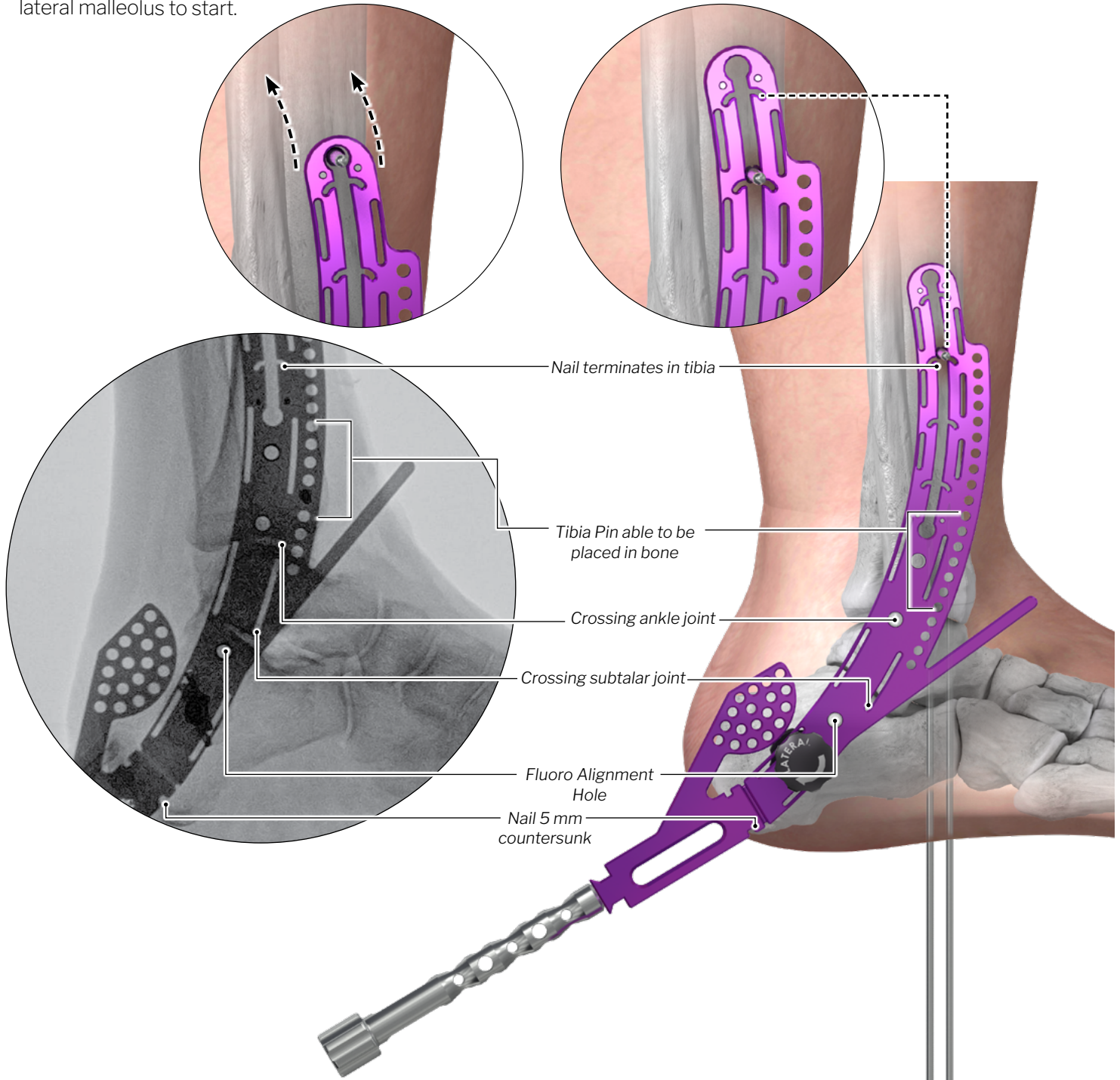

Under lateral fluoroscopy, pivot the template around the Tibial Sphere Pin to achieve the final nail trajectory. Confirm a true lateral view of both the ankle and the Template, adjusting the proximal and distal ends separately if needed.

Verify the templating goals (pg. 11). If this alignment cannot be achieved, reposition of Tibial Sphere Pin.

TEMPLATE PLACEMENT - ANKLE JOINT ALIGNMENT:

Place a Ø3.0 Pin in any of the anterior holes of the Template that would allow the Pin to be placed in the tibia. After placing the Pin in the tibia, confirm position of the Template on fluoroscopy.

Ø3.0 X 160 mm Guide Drill Pin

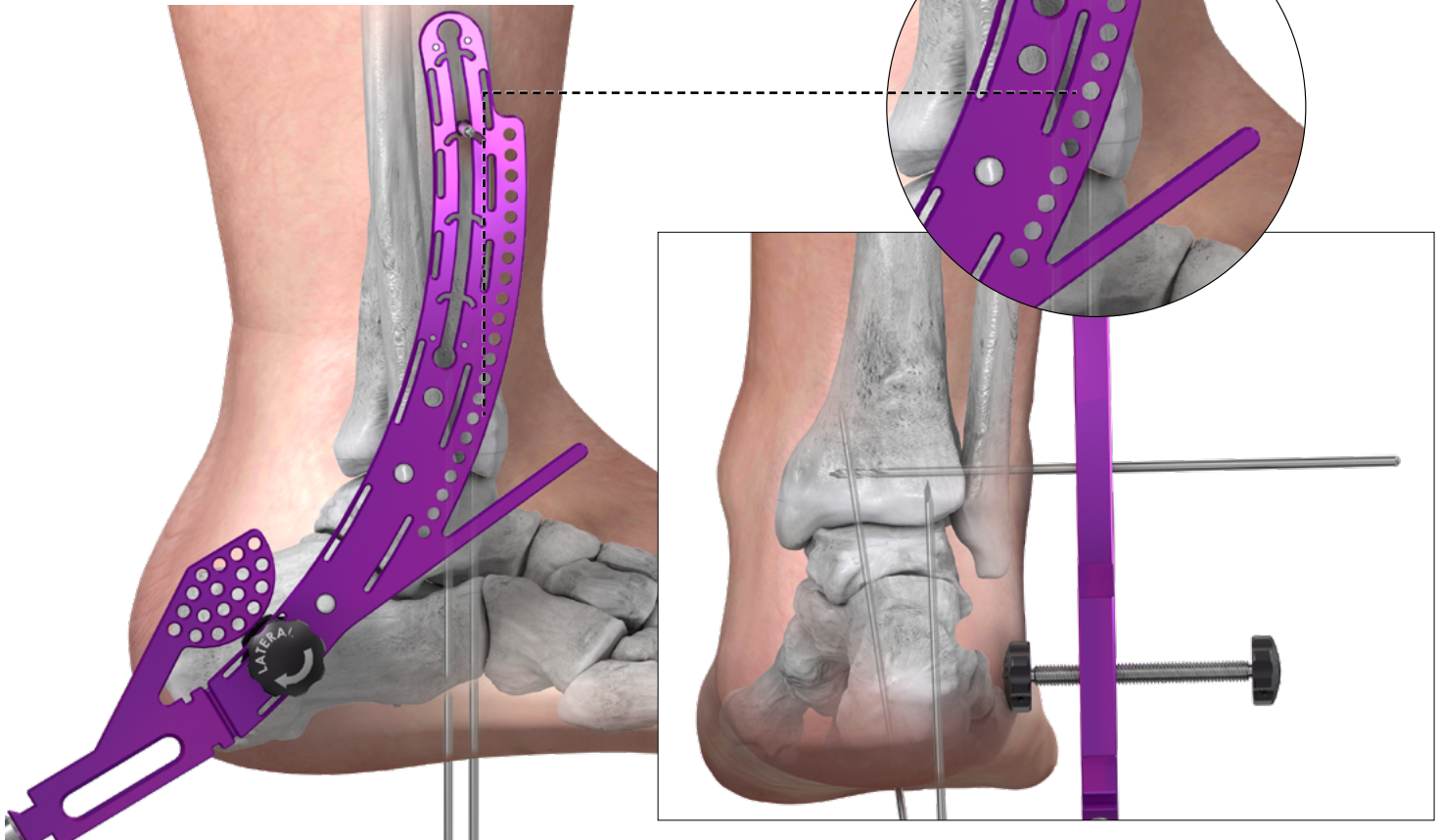

Assemble the Angel Wing by threading the Threaded Rods into the frame. Place the Angel Wing into one of the Tibial Pin holes on the Reamer Template. The Angel Wing will be used to determine where the implant crosses the ankle joint and entry point in the calcaneus. Per surgeon preference, not all 4 threaded rods need to be added to the frame, but there needs to be at least one on each side.

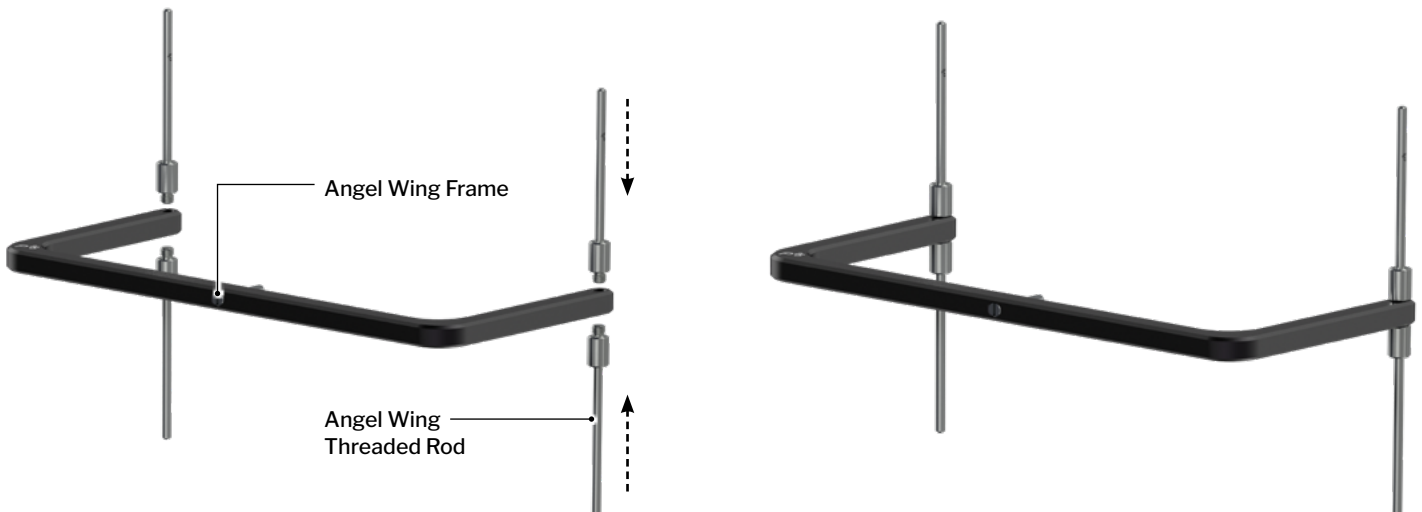

TEMPLATE PLACEMENT - ANKLE JOINT ALIGNMENT:

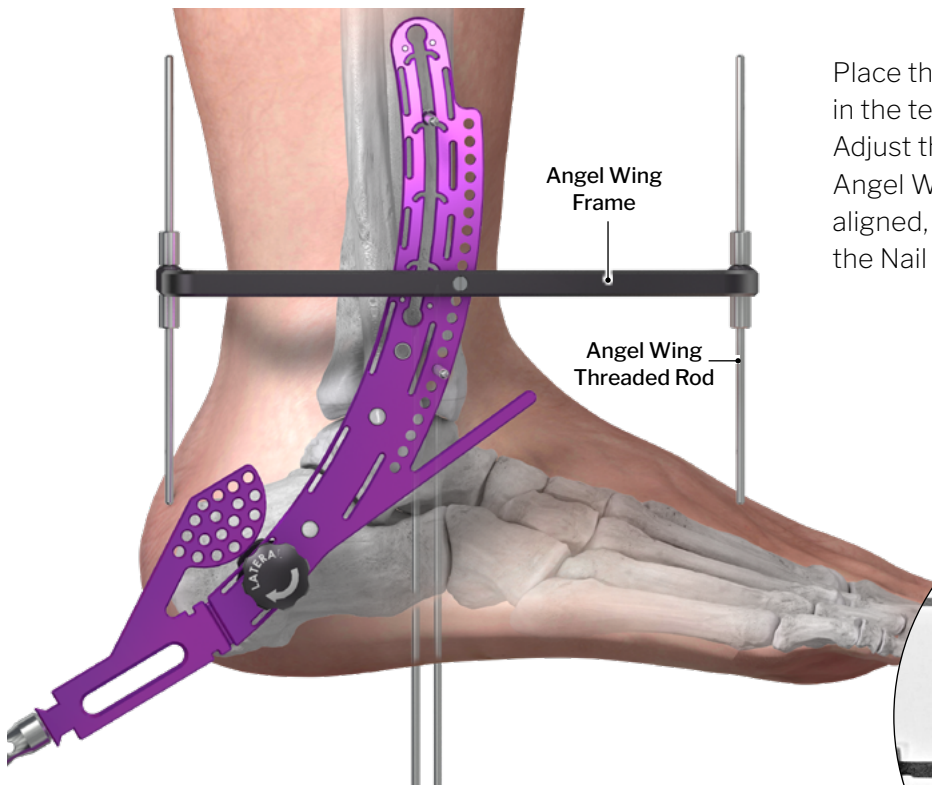

Place the assembled Angel Wing distal enough in the template to visualize the tibiotalar joint. Adjust the fluoroscopy so that both rods of the Angel Wing align. When the Angel Wings are aligned, that corresponds to the trajectory of the Nail through the talus and into the tibia.

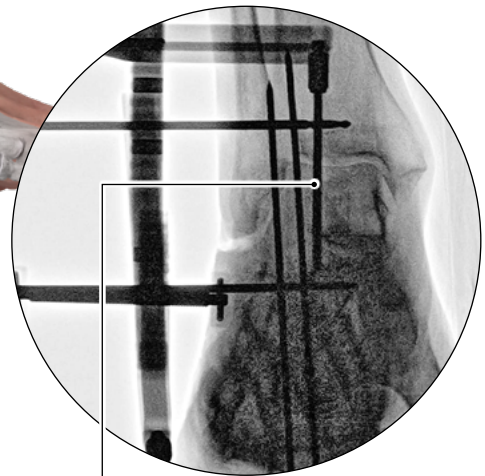

NOTE: Angel Wings aligned and positioned in middle 1/3 of joint space.

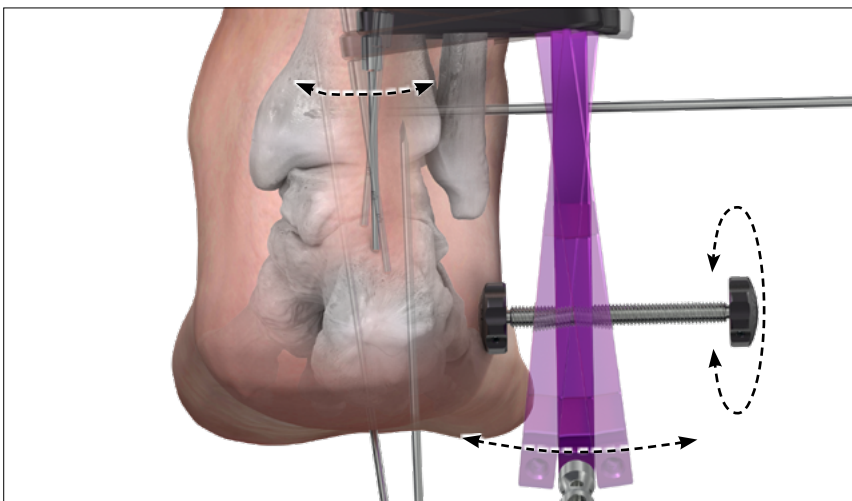
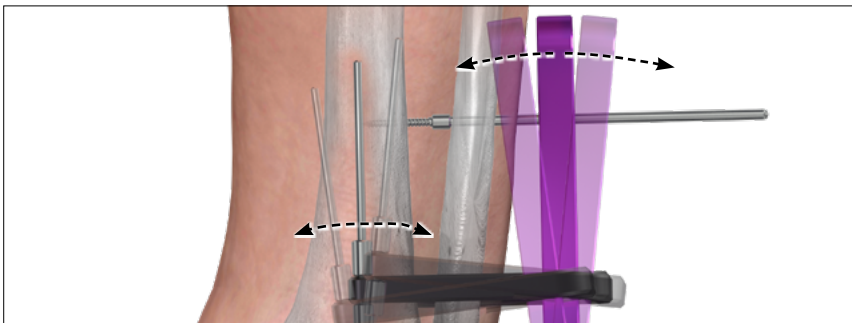

- ▶ Proximal Angel Wing pointing medial
- Back out Tibial Sphere Pin.
- ▶ Proximal Angel Wing pointing lateral
- Advance Tibial Sphere Pin.
- ▶ Distal position
- Turn M/L Knob on template.
- ▶ Target
- Angel Wings align within middle 1/3 of joint space.

Confirm the appropriate intended path of the Nail with the aligned Angel Wings.

TEMPLATE PLACEMENT - CALCANEAL ENTRY POINT: _____

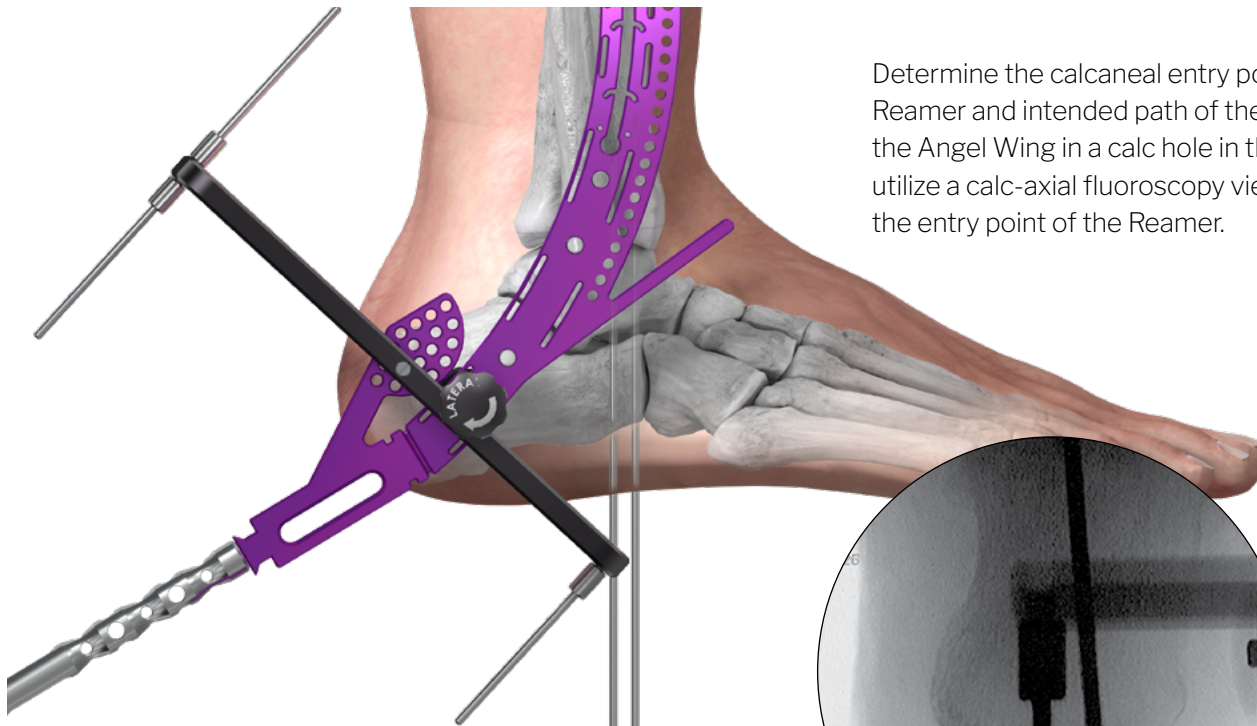

Determine the calcaneal entry point of the Reamer and intended path of the Nail by placing the Angel Wing in a calc hole in the Template and utilize a calc-axial fluoroscopy view to determine the entry point of the Reamer.

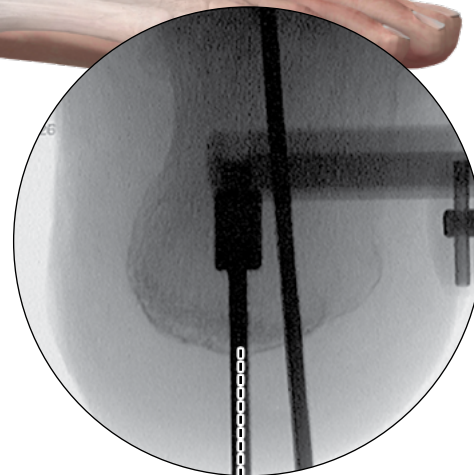
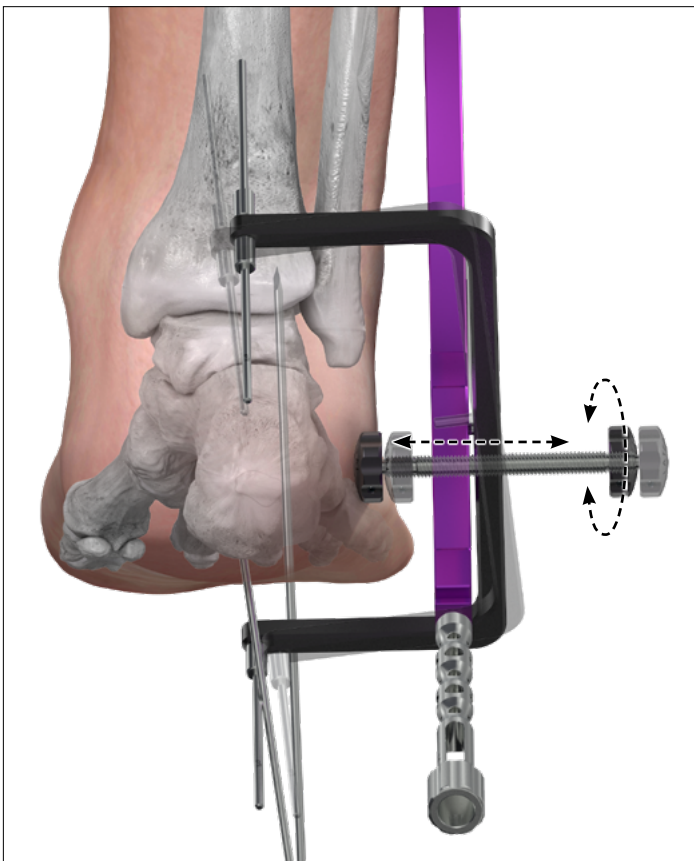

More medially biased

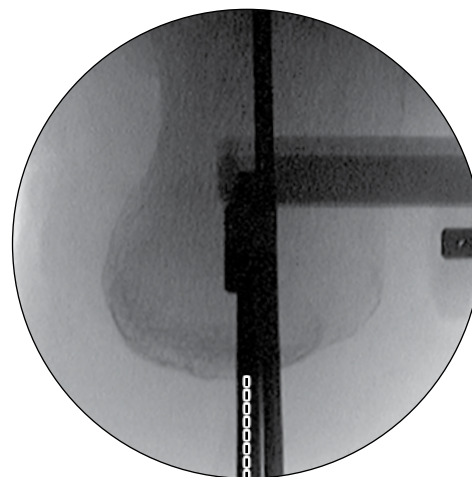

More centered

The entry point can be adjusted by turning the medial/lateral adjustment knob. Once the appropriate calcaneal entry point and intended Nail path is determined, place a Ø3.0 Pin into the calcaneus in one of the calcaneal holes on the Template.

TEMPLATE PLACEMENT - FINAL CONFIRMATION:



Ø3.0 X 160 mm Guide Drill Pin

After securing the Template with a Ø3.0 Pin into the tibia and with a Ø3.0 Pin into the calcaneus, double check the lateral, AP, and Calc-axial views to ensure the Template has not moved and the intended path and end point of the Nail are appropriate.

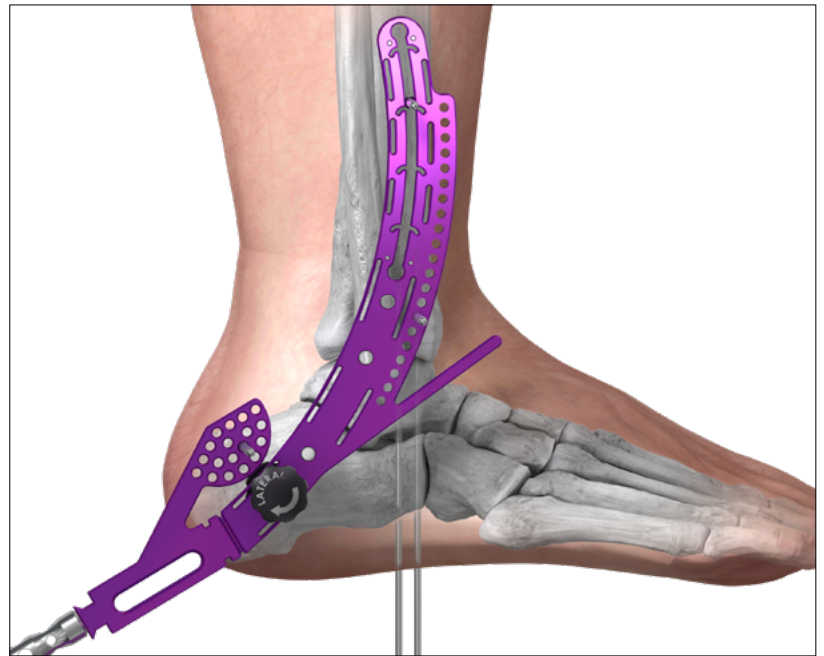

If smaller adjustments are still needed, remove one of either the tibial or calcaneal Pins and then re-insert after aligning. If gross adjustments are needed, remove all Pins and begin templating again.



CHECKLIST:

- ✓ Nail end point centered in Tibia
- ✓ Nail crossing both joints
- ✓ Nail endpoint positioned correctly in calcaneus
- ✓ Nail appropriately countersunk

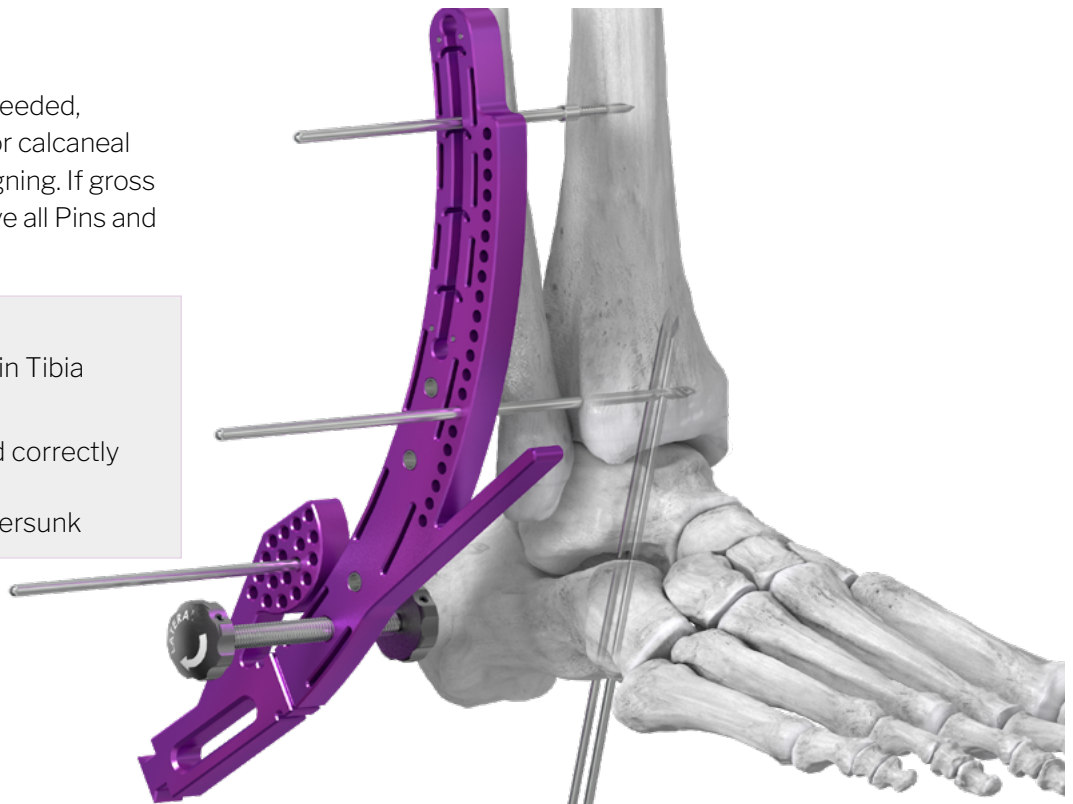

REAMING OUTRIGGER - ASSEMBLY:

After confirming proper position, remove the handle and attach the Reamer Outrigger to the Template by sliding the Outrigger into the end of the Template over the dovetail attachment of the Template. Push in on the knob and turn clockwise to secure it to the Template. A stack of towels can be placed under the reaming Outrigger to help support the weight of the Outrigger.

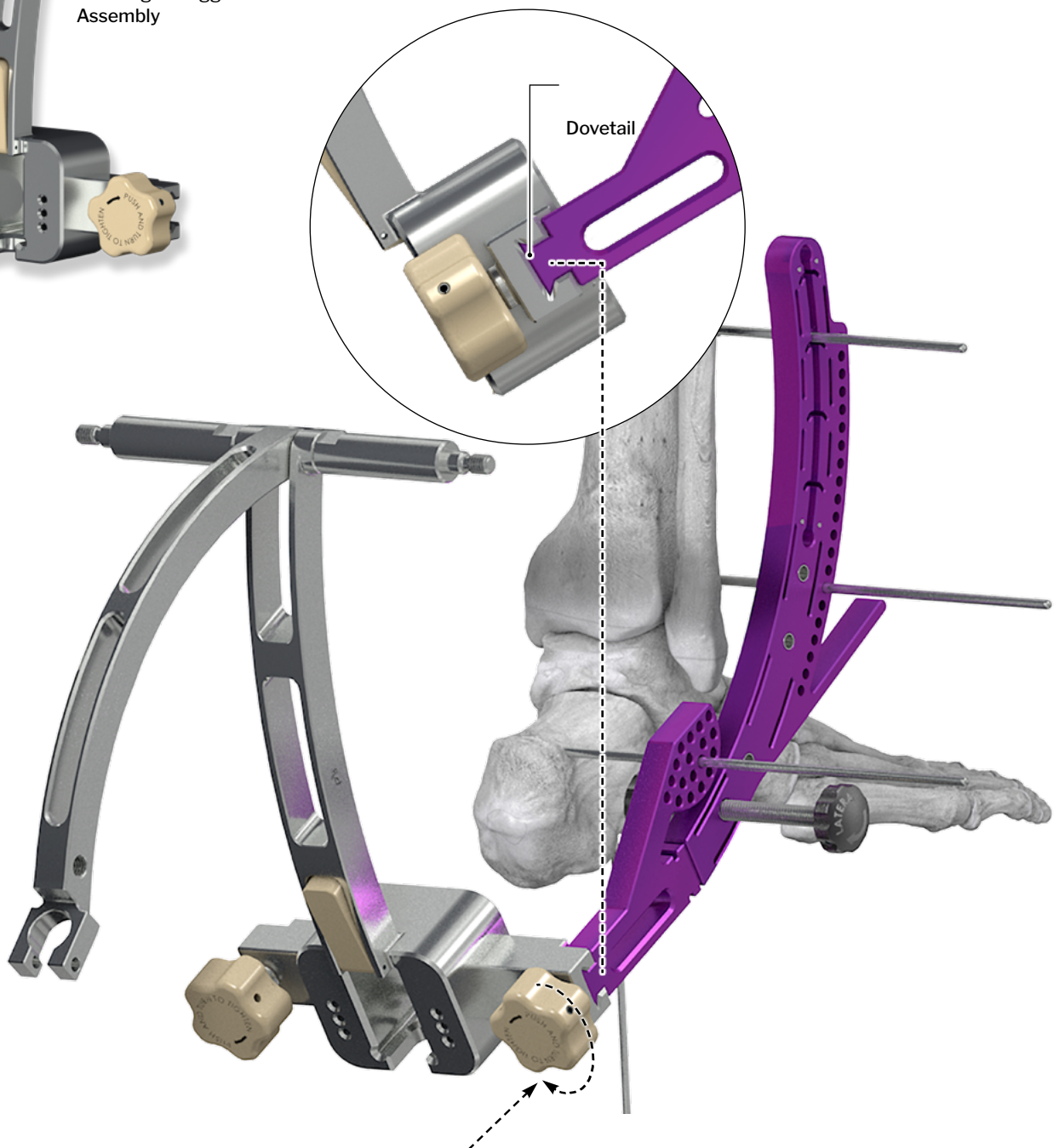

REAMING OUTRIGGER - ASSEMBLY:



Strut Support Offset Bar

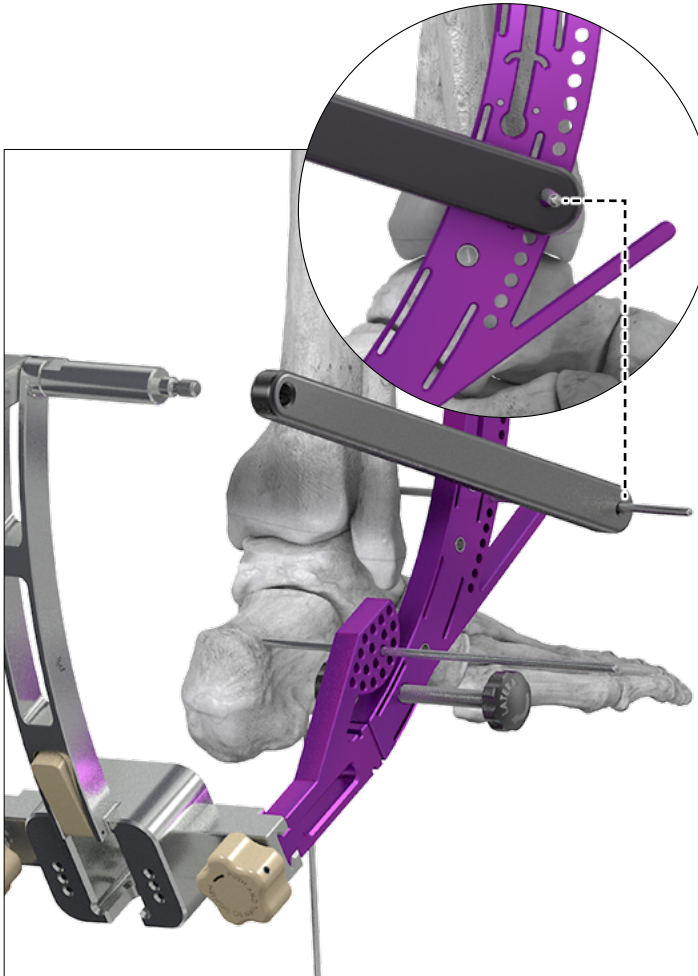

Slide the small hole of the Support Offset Bar over the Ø3.0 Tibial Pin.

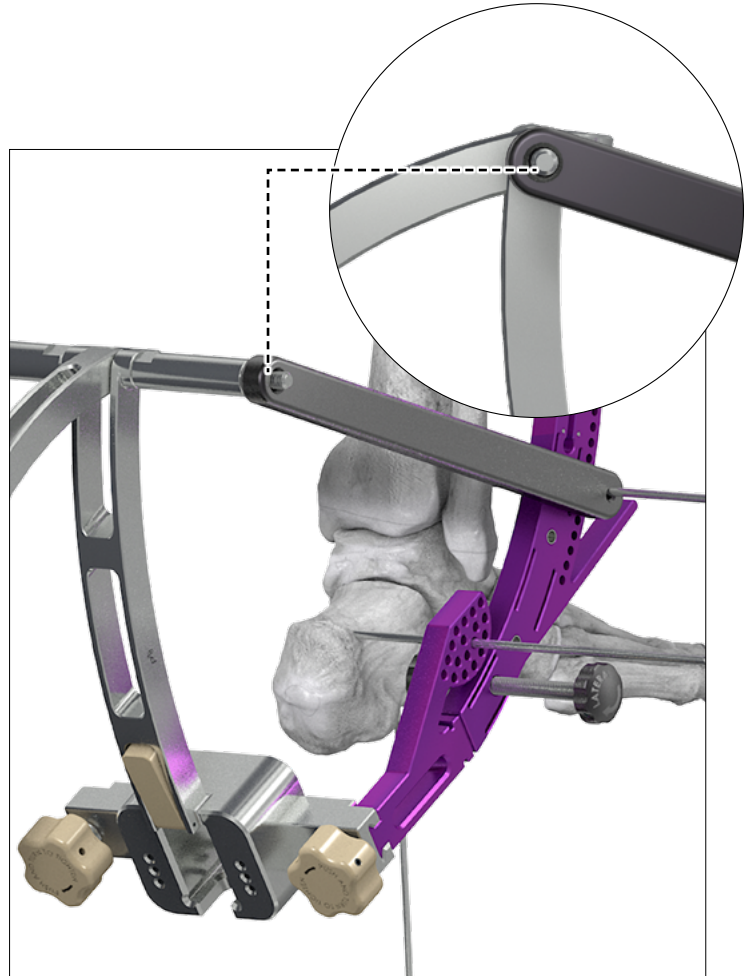

Once secured, place the larger hole of Strut Support Offset Bar over the threaded post of Reaming Outrigger Assembly.



Offset Bar Knob

Push in on the knob and turn clockwise to secure it to the Template.

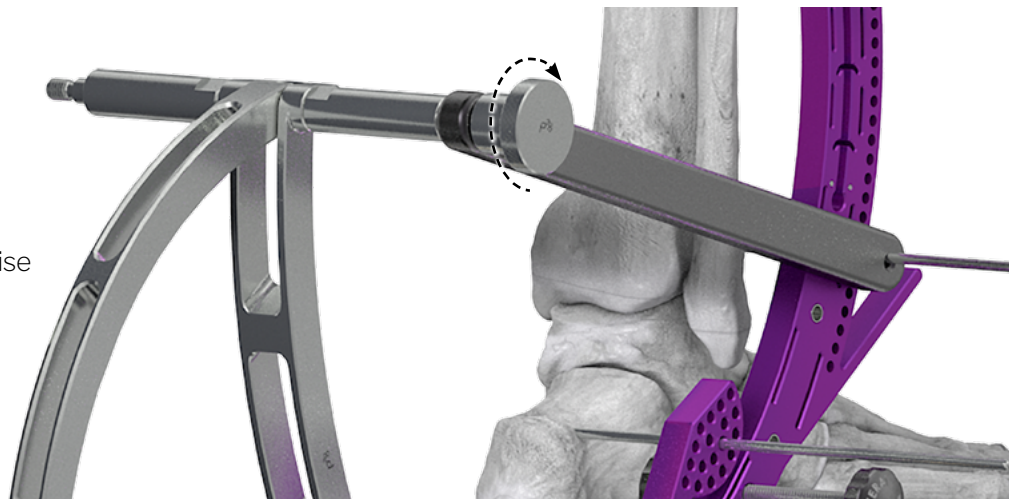

REAMING OUTRIGGER - ASSEMBLY:



K-wire Cartridge

Slide the K-wire Cartridge into the Reaming Outrigger until it clicks into place.

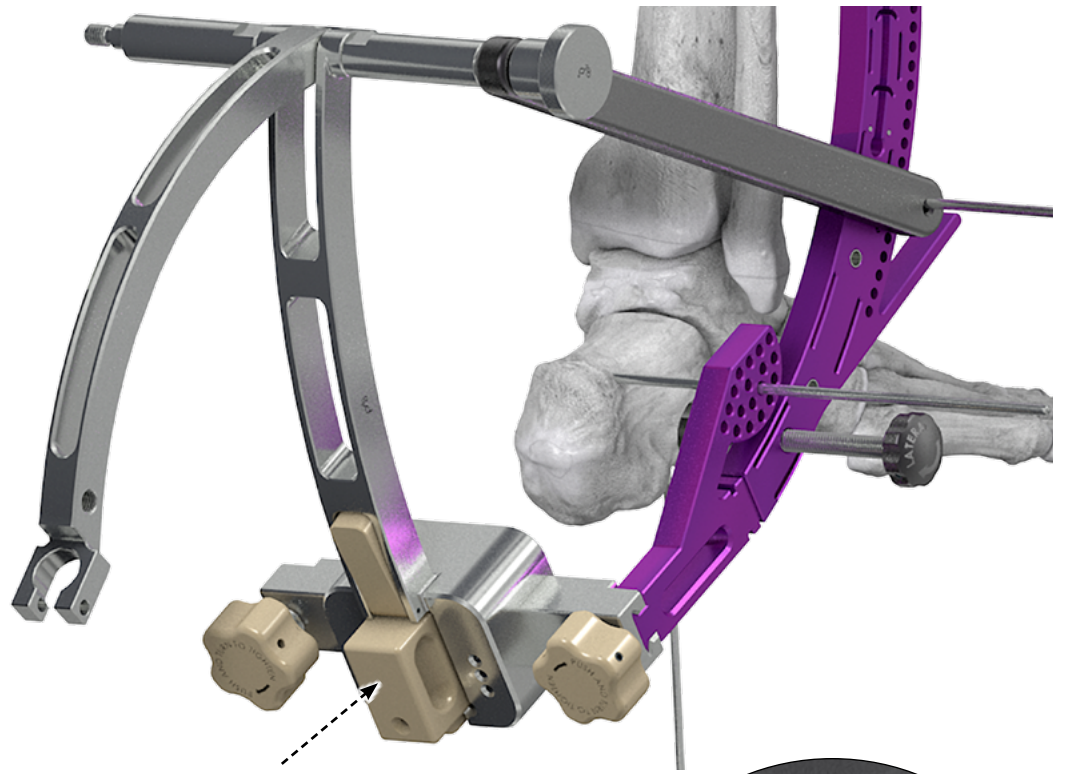

Ø2.3 x 230 mm Smooth, Single-Ended Trocar Tip K-wire

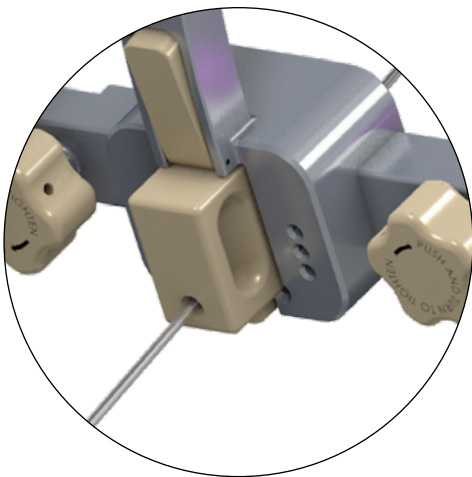

Place a Ø2.3 mm wire through the cartridge against the skin. Utilize a calc-axial fluoroscopy view to confirm the entry point of the Wire, which will also be the entry point of the Reamer.

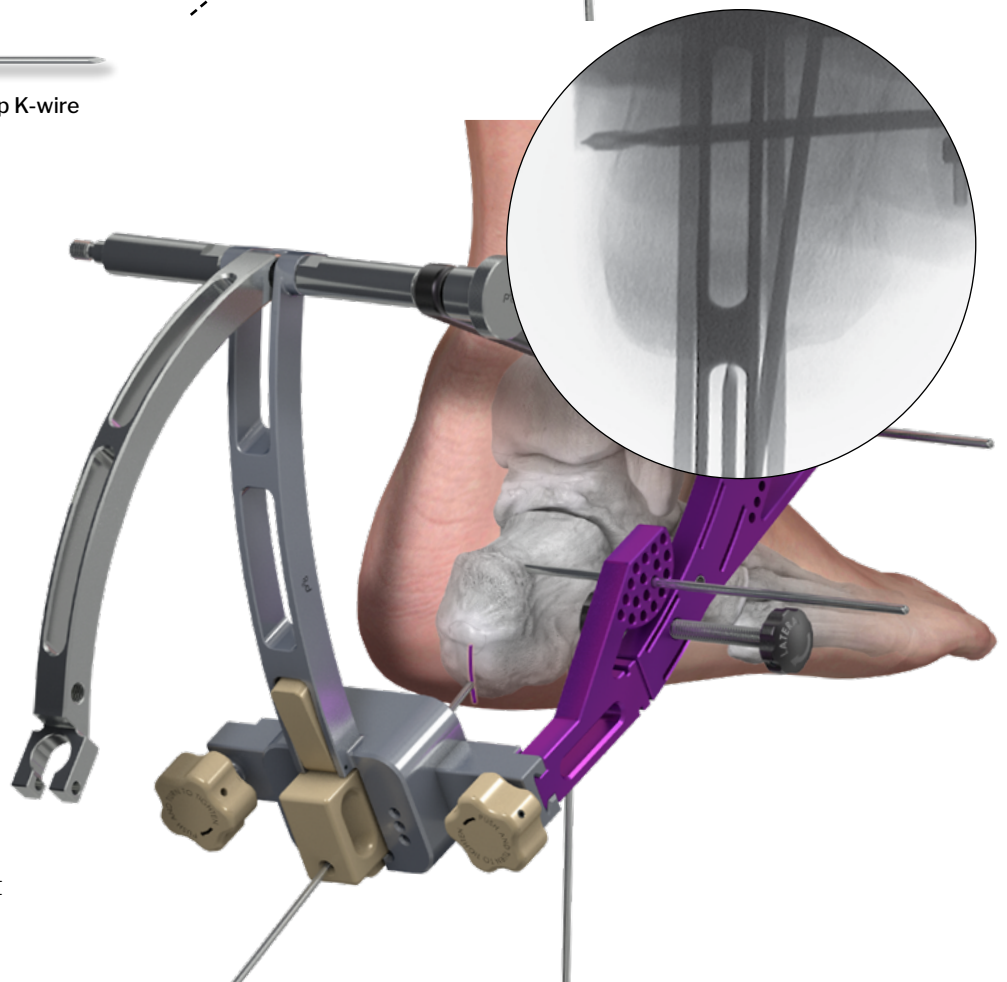

REAMING OUTRIGGER - ALIGNMENT:

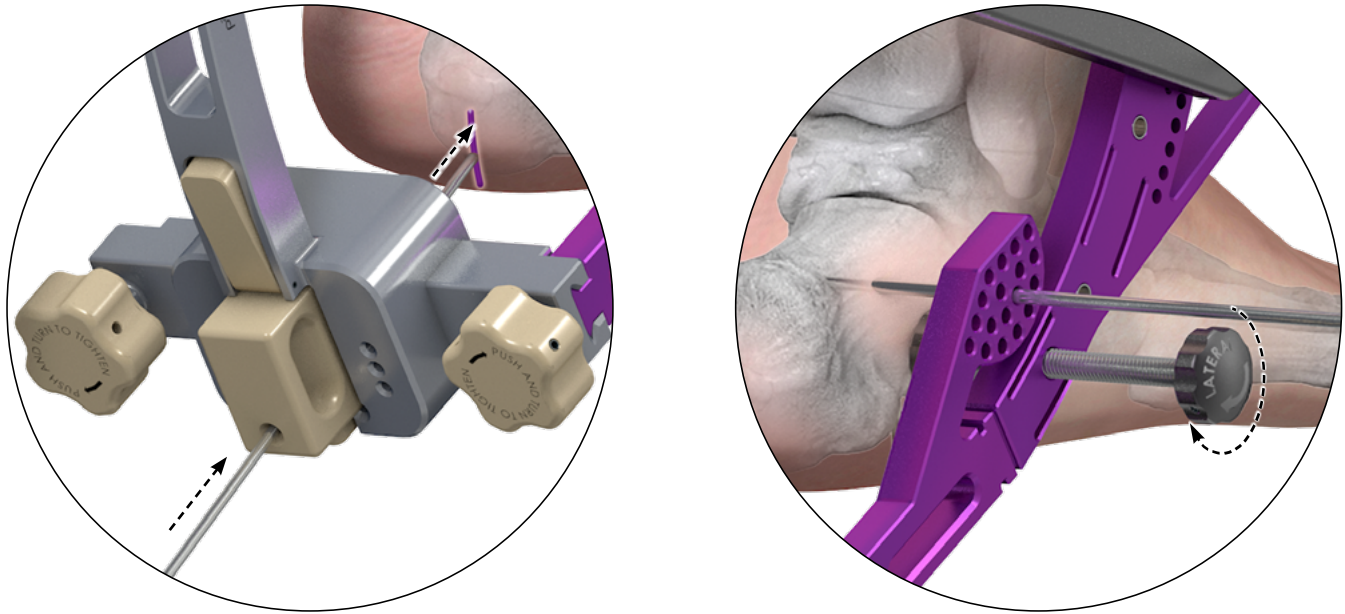

Ensure the Wire isn't biased too medial or lateral in the calcaneus. Minor adjustments can be made to the alignment using the knob on the Reaming Template. Make an incision where the K-wire contacts the skin. Insert the $\text{\O}2.3$ mm wire through the cartridge and into the calcaneus to help secure the Outrigger.

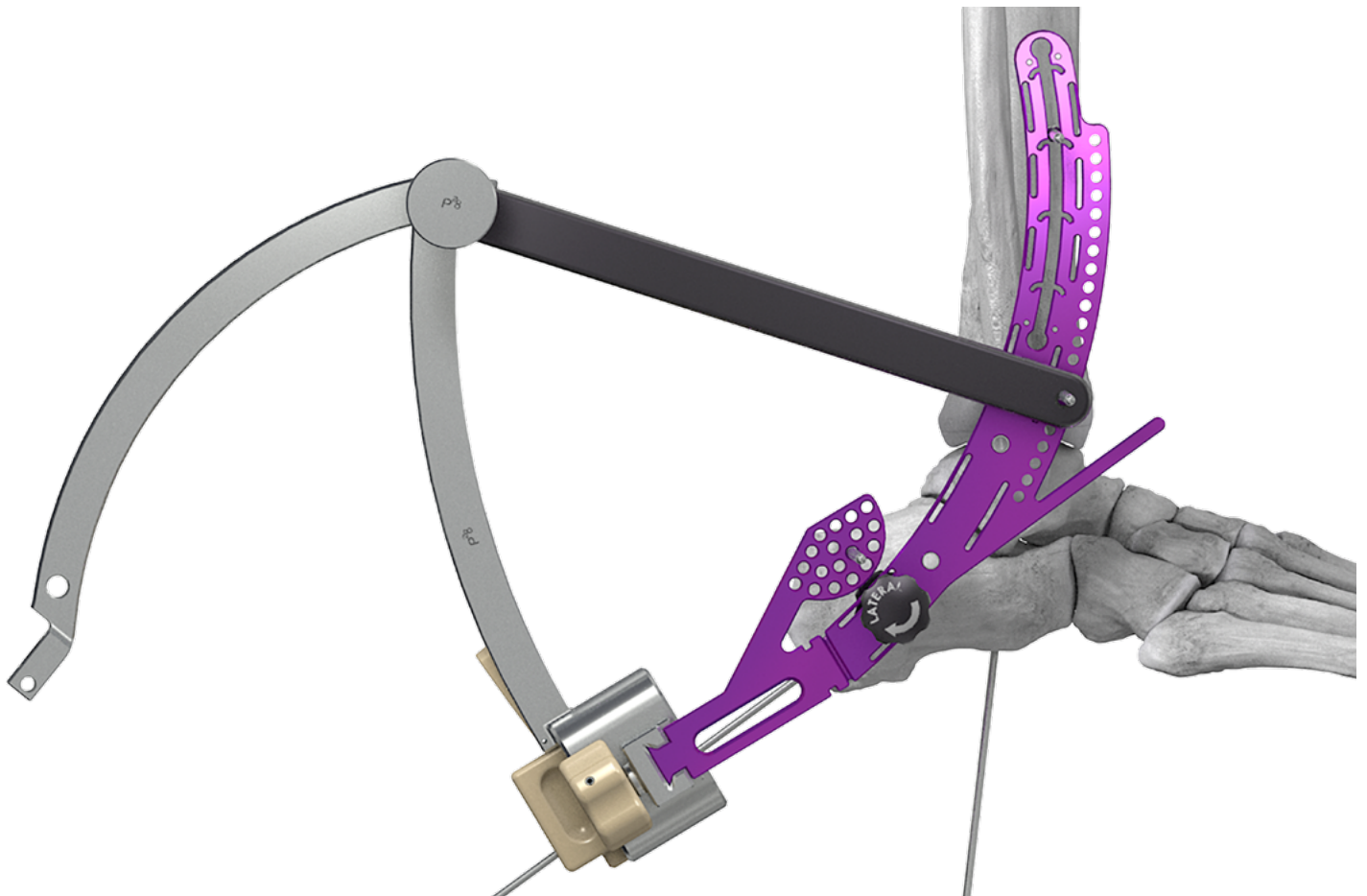

REAMING OUTRIGGER - ALIGNMENT:

Ø2.3 x 230 mm Smooth, Single-Ended Trocar Tip K-wire

Once the entry point is confirmed, secure the alignment in the calcaneus by placing an additional Ø2.3 mm Wire through one of the lateral holes next to the K-wire Cartridge in the Reaming Outrigger. Only one cortex purchase is necessary to secure it.

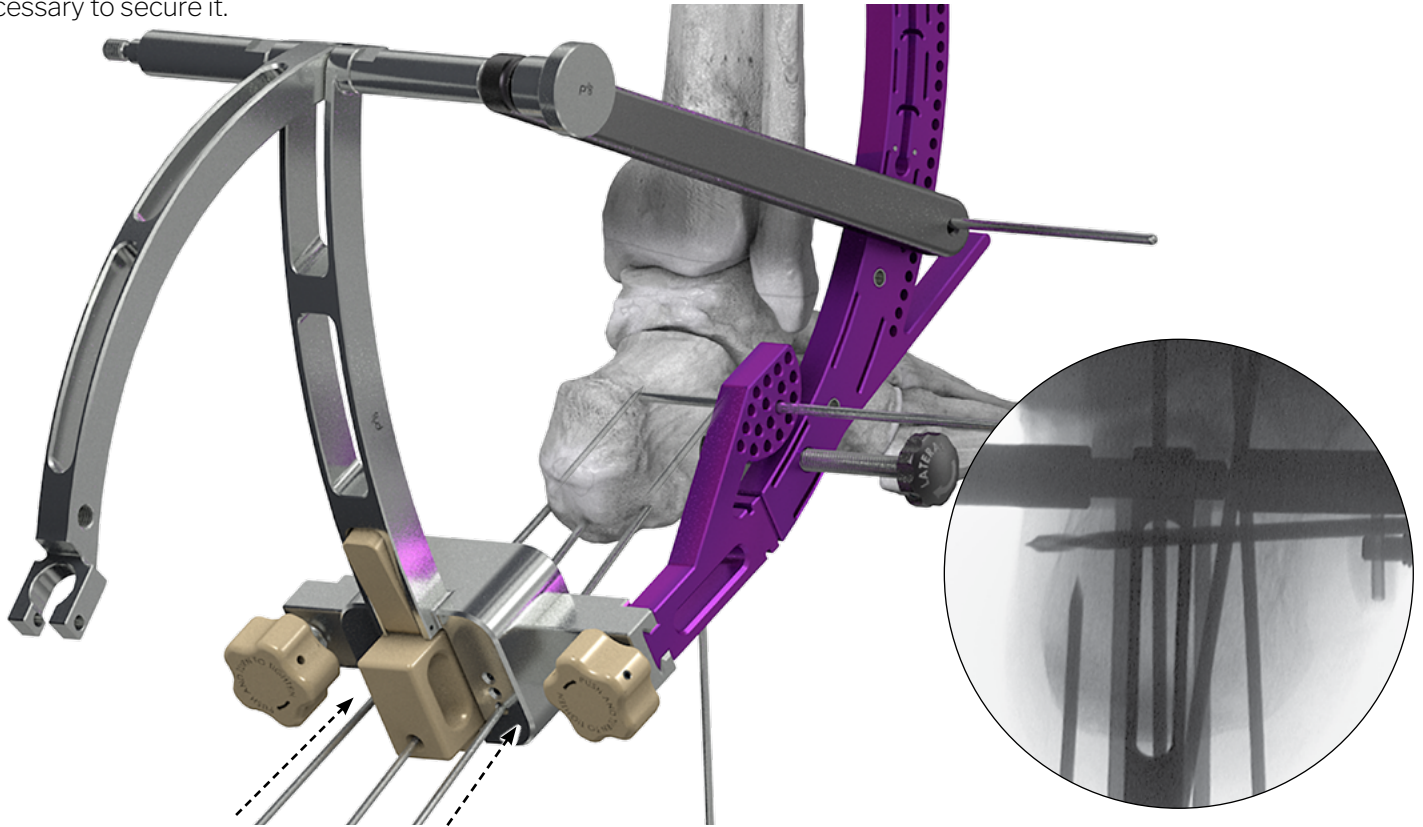

If placing a Wire through one of the medial holes, take care to ensure the Wire does not violate any nearby neurovascular structures. An additional Wire can be placed through one of the other lateral holes if more fixation is needed and a medial Wire is not wanted to be placed.

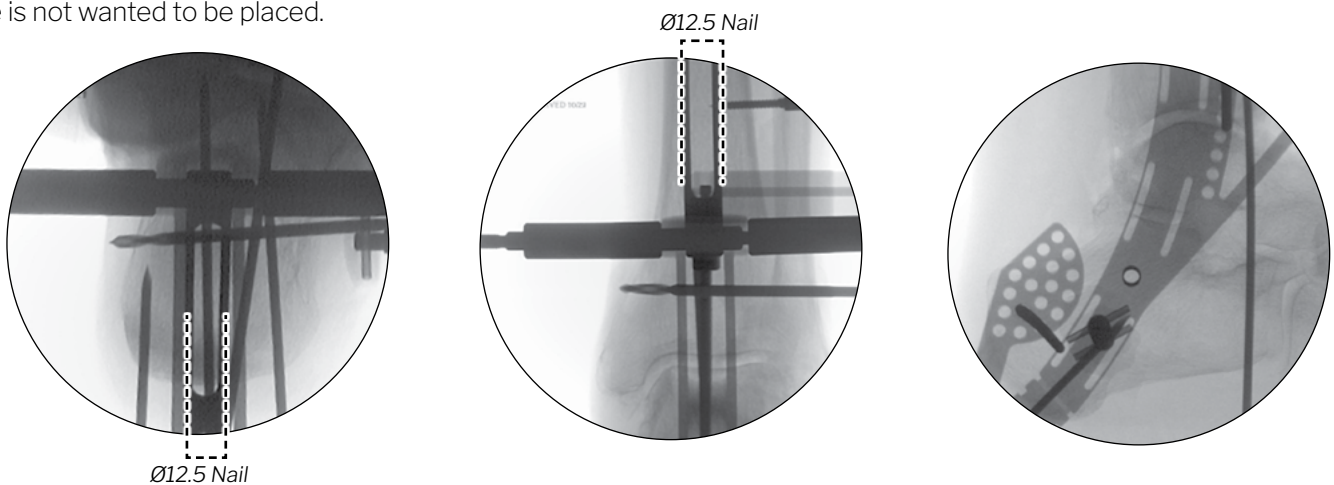

Double check alignment of the Template with all fluoroscopy views (Lateral-Medial, Anterior-Posterior, and Calc Axial). When checking AP alignment and calc entry point, the Angel Wing or wire should be in the middle of the bars of the Reaming Outrigger under fluoroscopy. The darker bars of the reaming Outrigger also correspond to the diameter of the Ø12.5 Nail, and should be seen within the calcaneus, talus, and tibia under fluoroscopy.

IMPLANT REAMING - ENTRY REAMING:



7 mm Reamer Entry Countersink

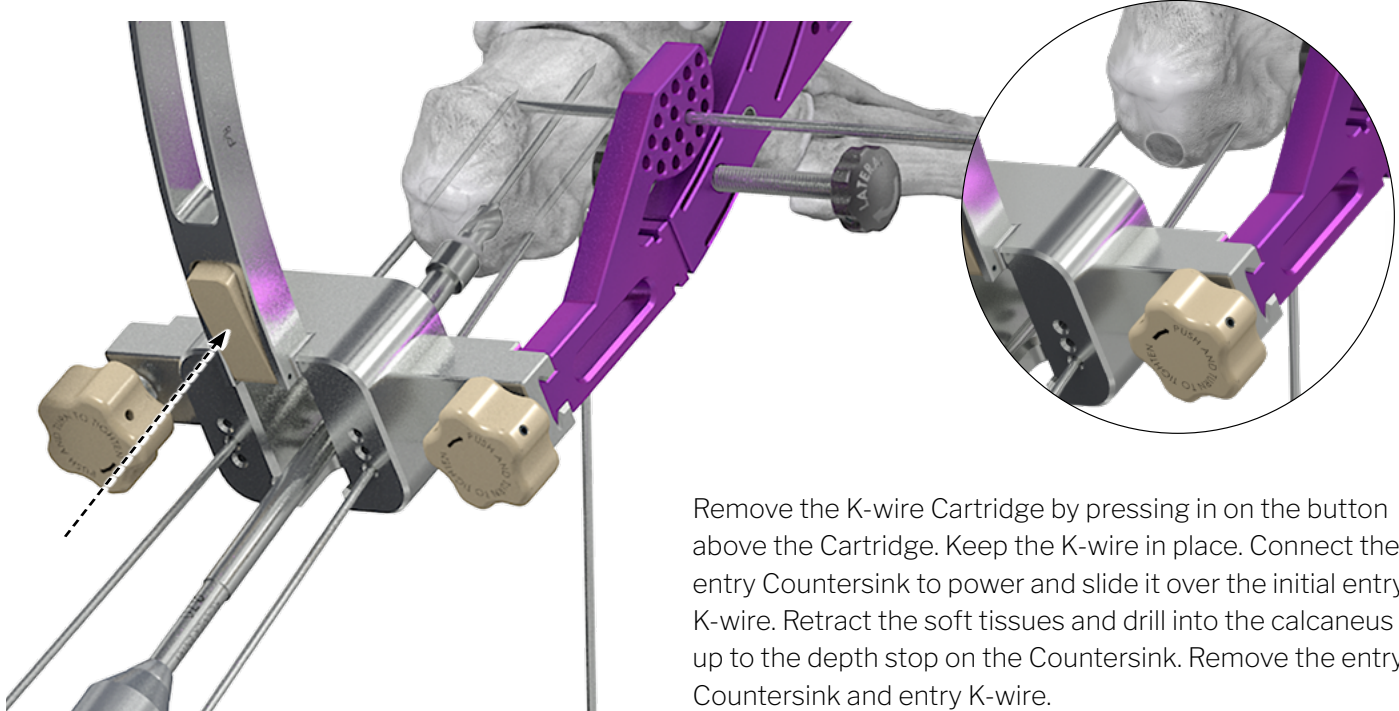

Remove the K-wire Cartridge by pressing in on the button above the Cartridge. Keep the K-wire in place. Connect the entry Countersink to power and slide it over the initial entry K-wire. Retract the soft tissues and drill into the calcaneus up to the depth stop on the Countersink. Remove the entry Countersink and entry K-wire.



Reamer Cartridge



Grenade Pin

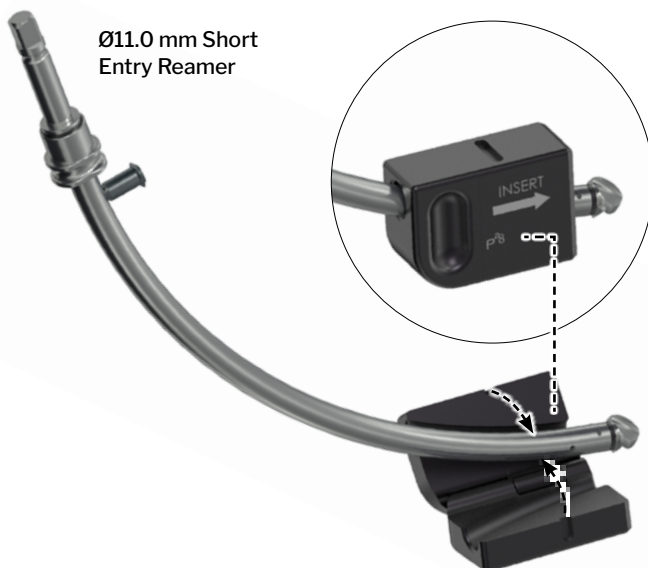

Ø11.0 mm Short Entry Reamer

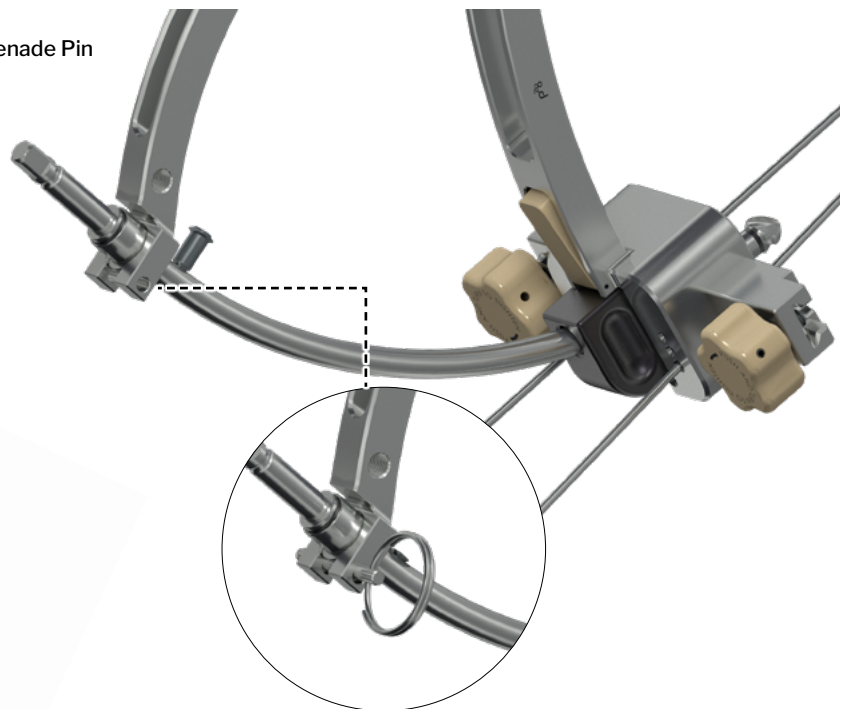

Remove the reamer cap and place the Ø11.0 mm short throw Reamer into the reaming cartridge.

Insert the cartridge into the reaming Outrigger and secure the back of the Reamer to the Outrigger using the Grenade Pin. The cartridge should click into place when secure.

IMPLANT REAMING - ENTRY REAMING:

Irrigation Tube



Torque Limiting Adapter



Attachment Handle

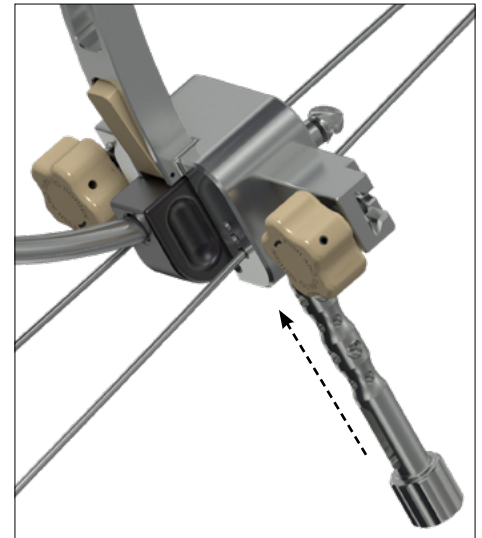

To set up irrigation, hang and spike at least a 500 mL saline bag (not provided) with the provided irrigation tubing and connect to the Reamer via the Leur connection.

Attach the Reamer to power via the provided torque limiting adapter. Stryker System 8, Stryker CD4, or Conmed Hall 50 power is required.

Attach the handle to the reaming Outrigger for additional leverage. Have suction available to remove irrigation contents. Verify irrigation is flowing through the reamer and exiting below the cutting head before continuing.

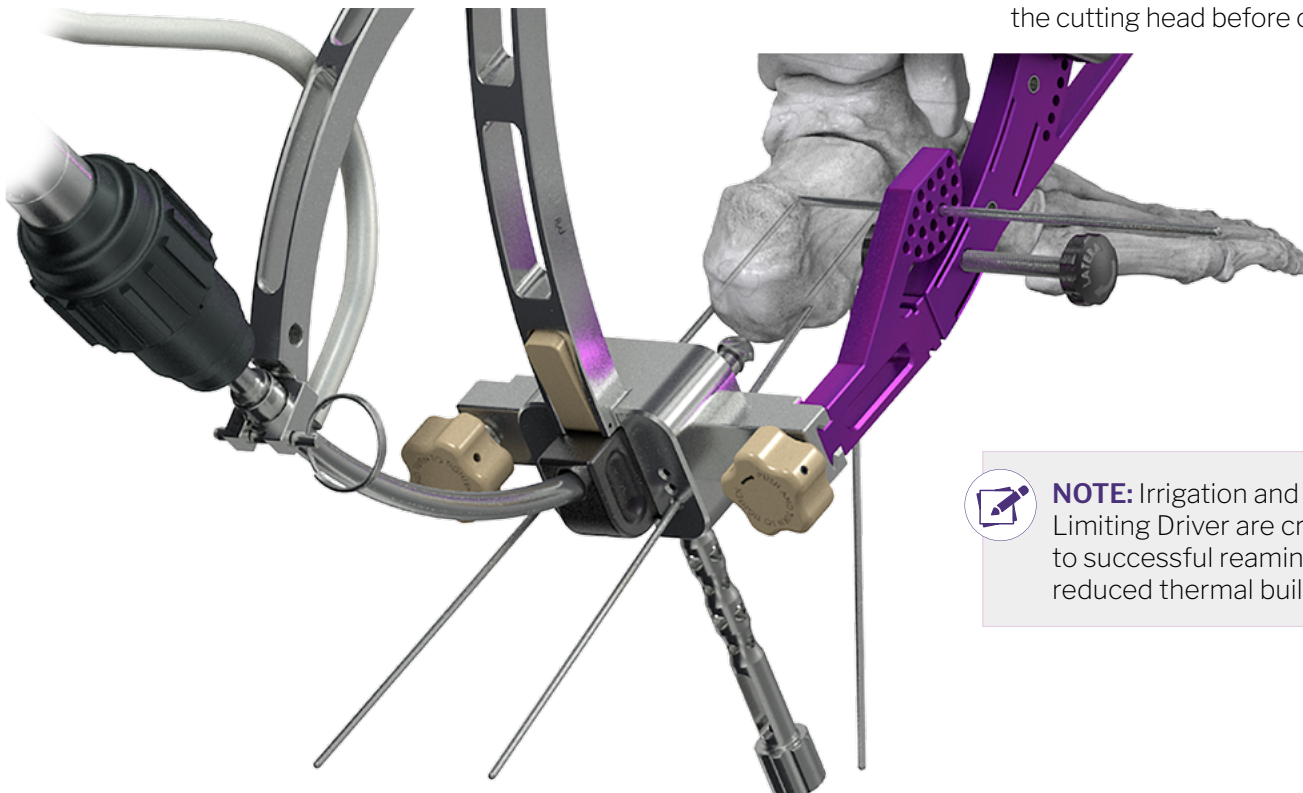

NOTE: Irrigation and the Torque Limiting Driver are critical to successful reaming with reduced thermal build up.

IMPLANT REAMING - ENTRY REAMING:

Ream under fluoroscopy to ensure the Reamer is following the correct path. It is recommended to peck drill with the Reamer. Retract soft tissue to place the reamer head against the bone and begin reaming with irrigation running. **Maintain sagittal plane alignment of the Reamer and avoid dropping the power unit medially.**

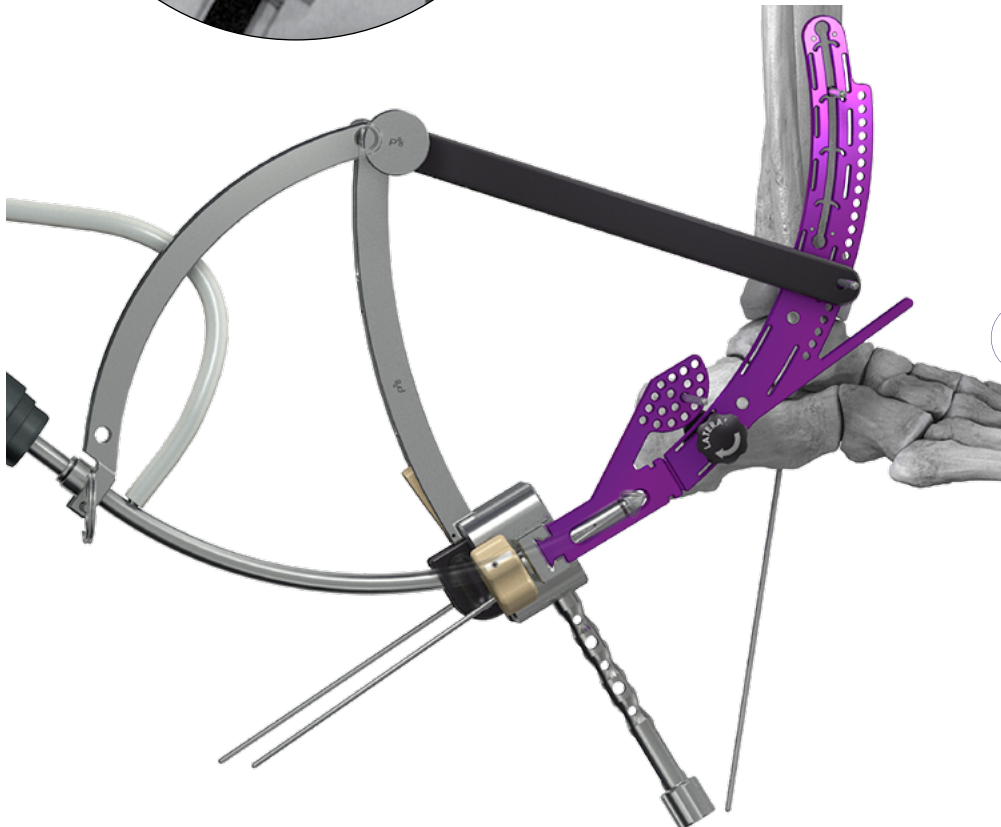
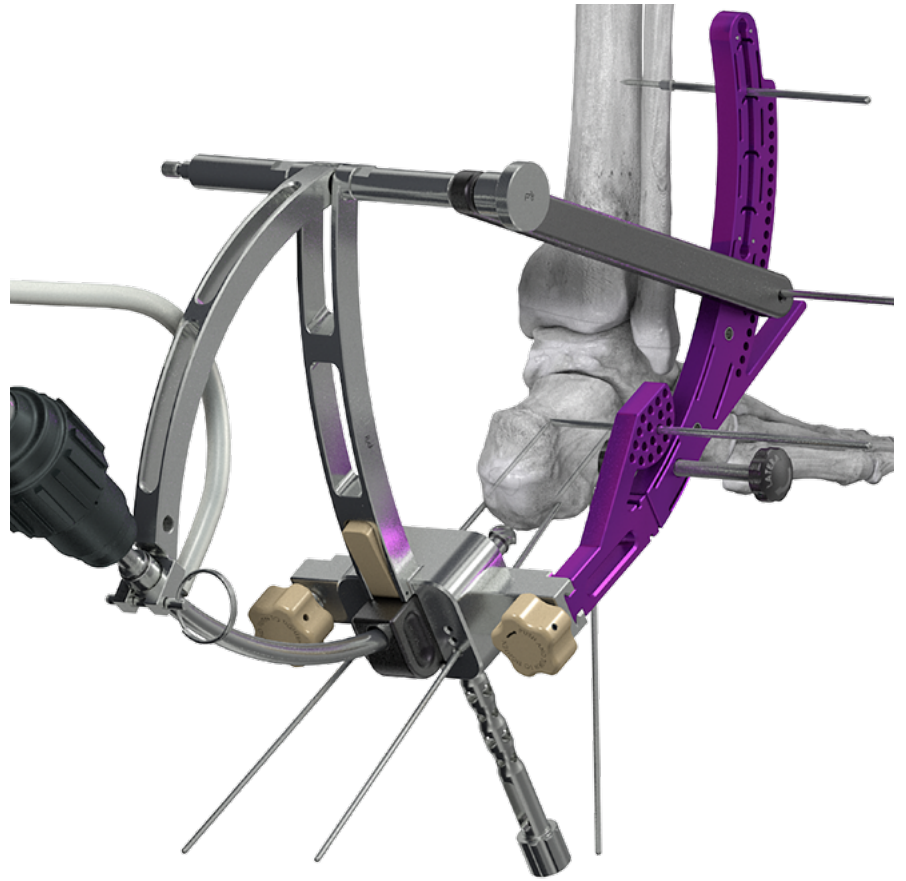
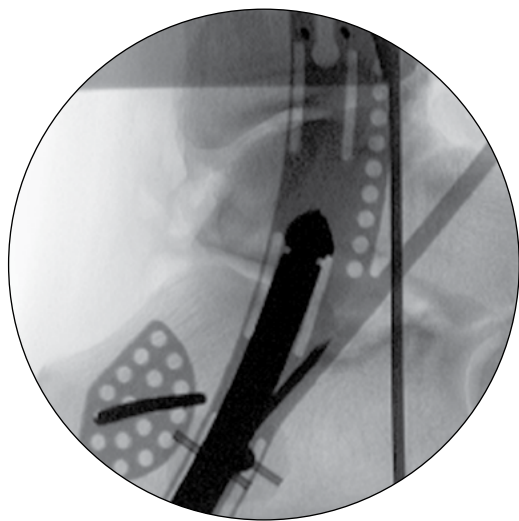

NOTE: If the initial Reamer is having difficulty, the larger Reamer size can be used for improved material evacuation. This is not recommended as the smaller Reamer followed by the larger Reamer helps reduce risk of bone/tissue necrosis.

IMPLANT REAMING - ENTRY REAMING:

Continue reaming with irrigation through the calcaneus, talus, and into the tibia going through the subtalar joint and the tibiotalar joint.

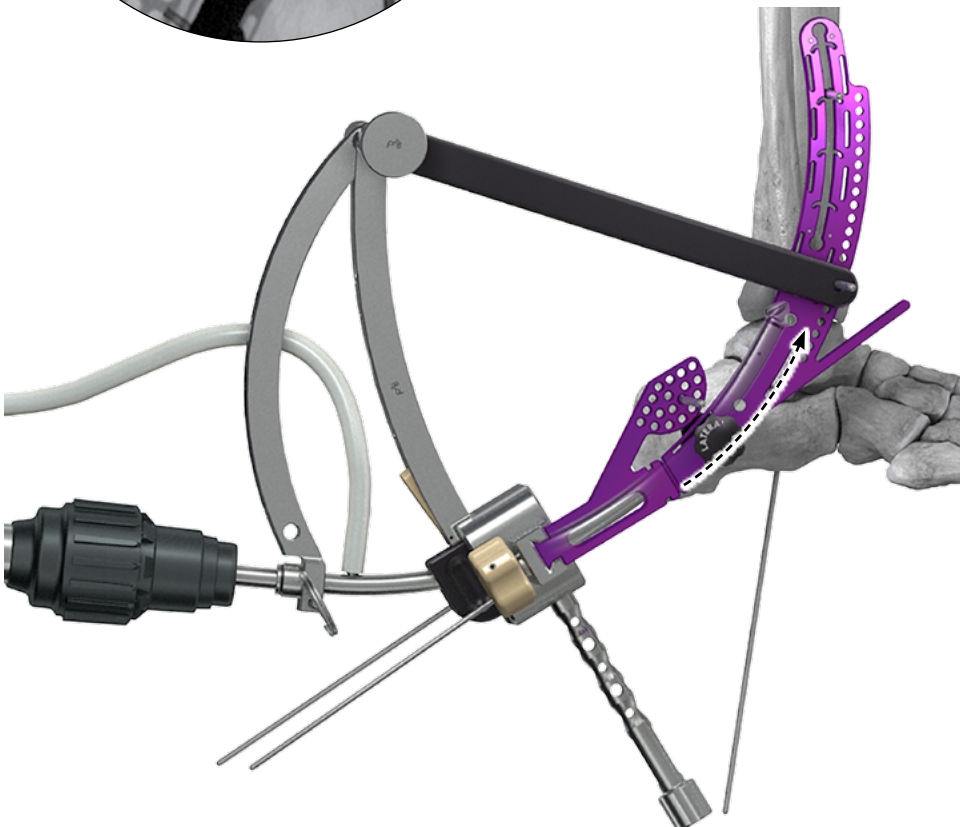
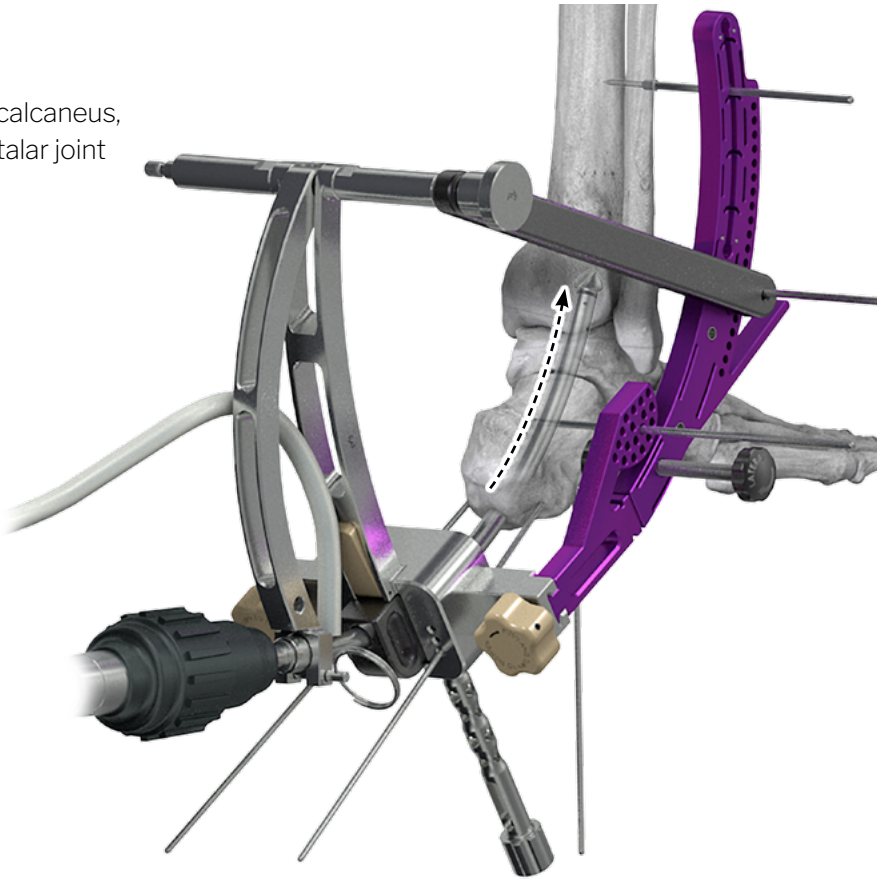
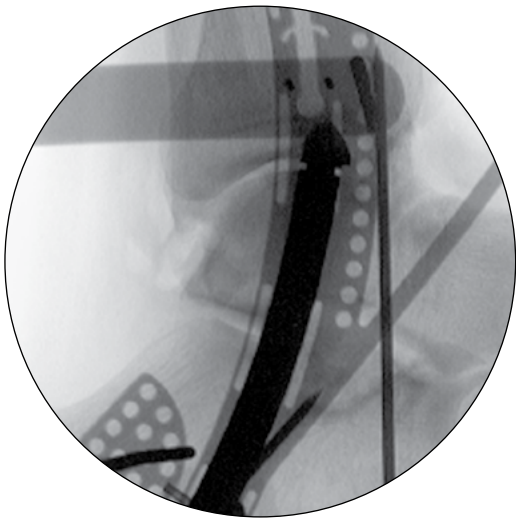

Stop reaming when the Reamer passes through the tibiotalar joint. If necessary, reposition the temporary fixation wire if it is blocking the path of the Reamer. Always confirm the path under fluoroscopy before removing the Reamer.

IMPLANT REAMING - FINAL REAMING:

Slap Hammer



1/4 Square Adapter



Reamer Slap Hammer Adapter



Thread a handle into the Outrigger swing arm. During removal, most of the pull back force should be on the handle with the opposite hand while continuing the Reamer under power and pulling backward. If there is difficulty with the Torque Limiting Driver, use the 1/4" square to tri-flat Adapter to back the Reamer out. The provided Slap Hammer can be attached to help back out the Reamer if necessary. Remove the Ø11.0 mm short throw Reamer.



Reamer Cartridge



Grenade Pin



Remove the reamer cap and place the appropriately sized Reamer for the intended Nail diameter into the reaming cartridge. Insert the cartridge into the reaming Outrigger and secure it to the Outrigger using the Grenade Pin.

Ø12.5 mm Reamer

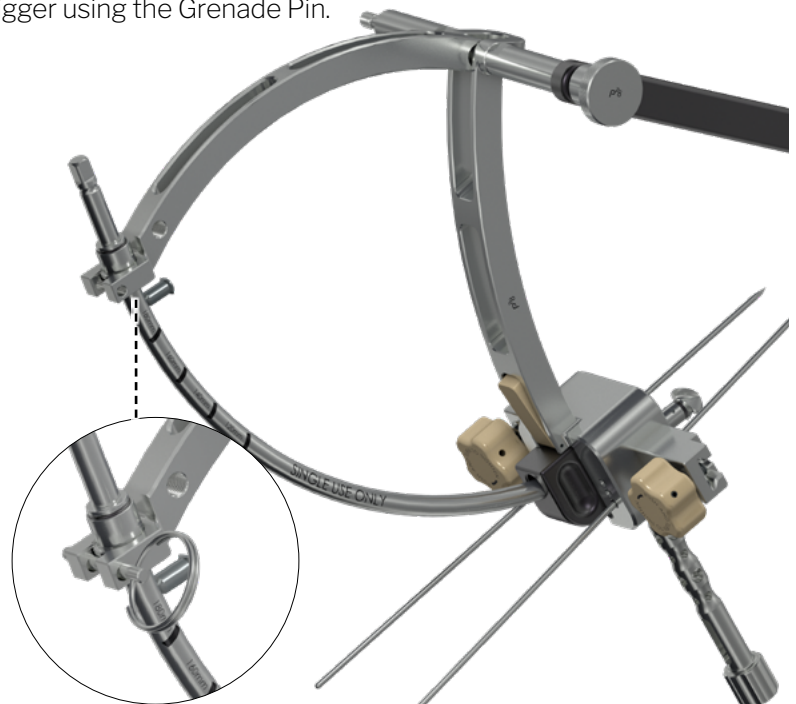
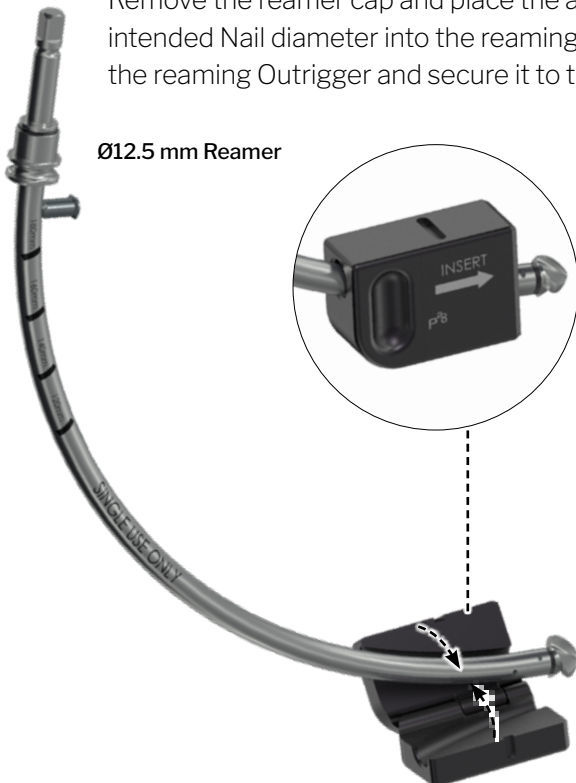

IMPLANT REAMING - FINAL REAMING:

Repeat reaming as described on pages 23-26 with the appropriately sized reamer for the intended nail. Stop reaming when the Reamer reaches the Tibial Sphere Pin marking the Nail termination point or the reamer has reached the appropriate depth based on the depth markings on the reamer. If necessary, reposition the temporary fixation wires if they are blocking the path of the Reamer.

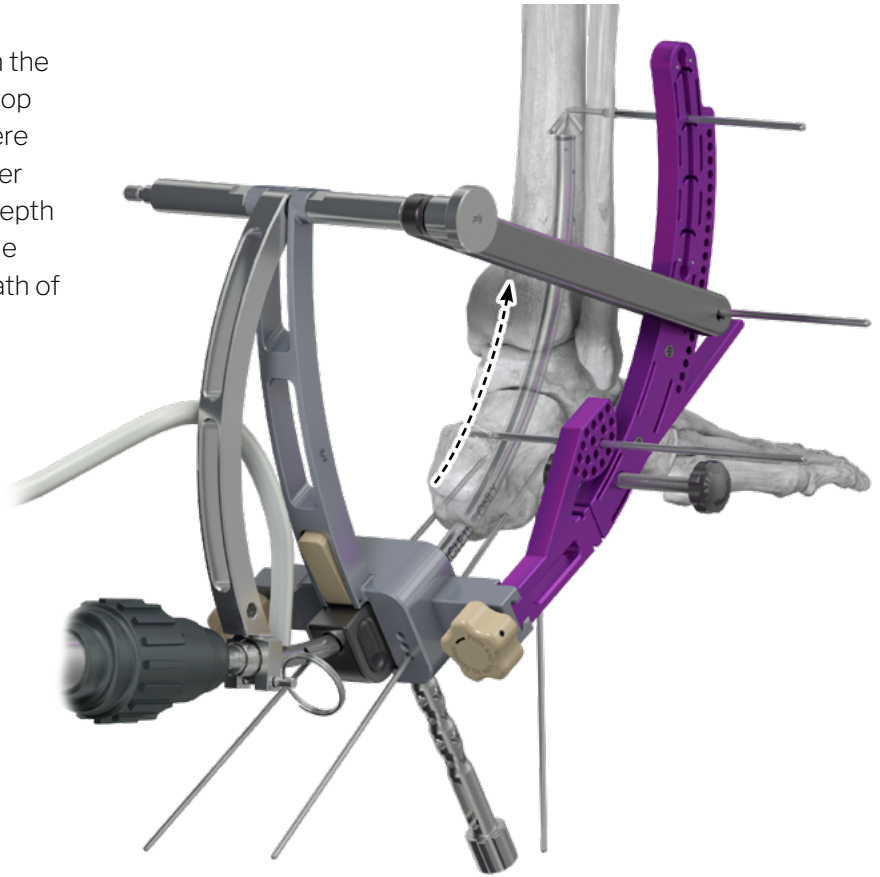
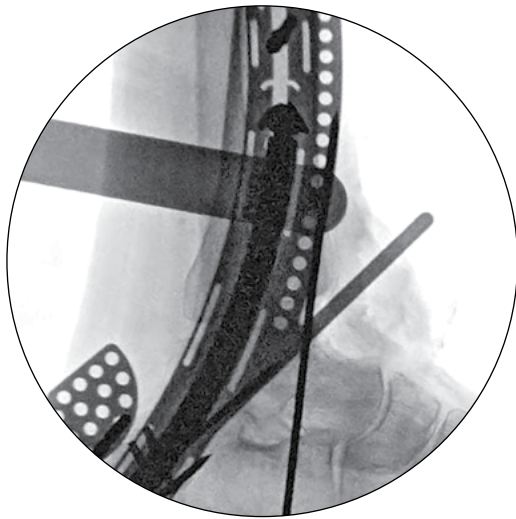

Always confirm the path under fluoroscopy before removing the Reamer.

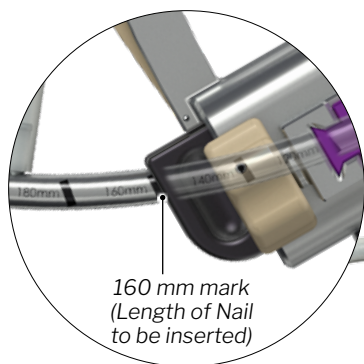

160 mm mark
(Length of Nail
to be inserted)

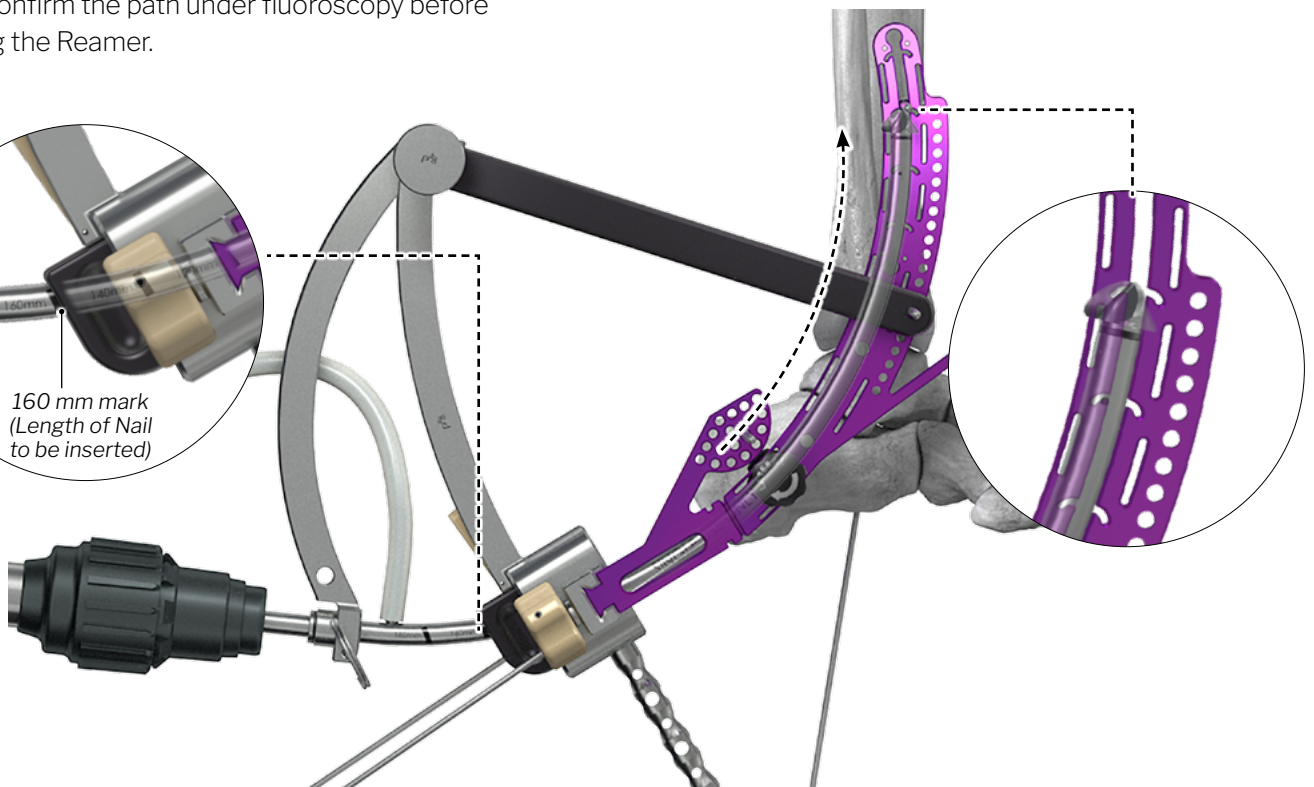

IMPLANT REAMING - FINAL REAMING:

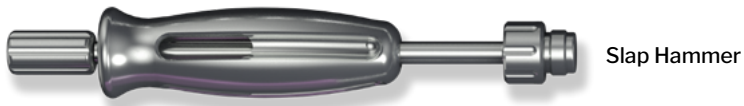

Reamer Slap Hammer Adapter



1/4 Square Adapter



Repeat reamer removal as described previously on page 27.

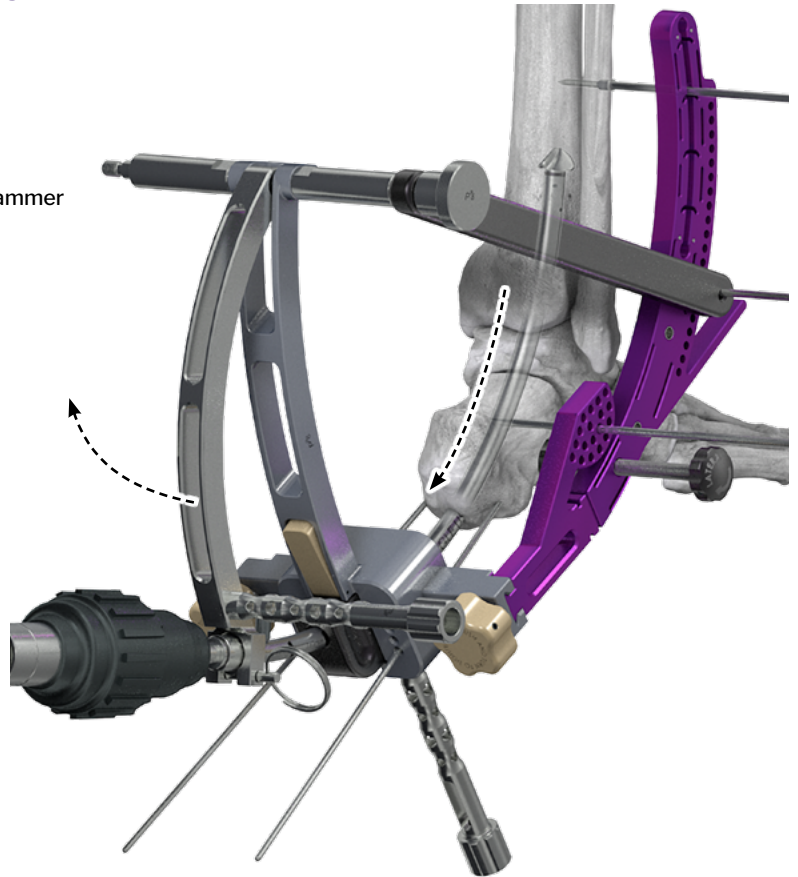

Remove all wires except the temporary fixation crossing wires and remove the Reaming Outrigger and Reaming Template.

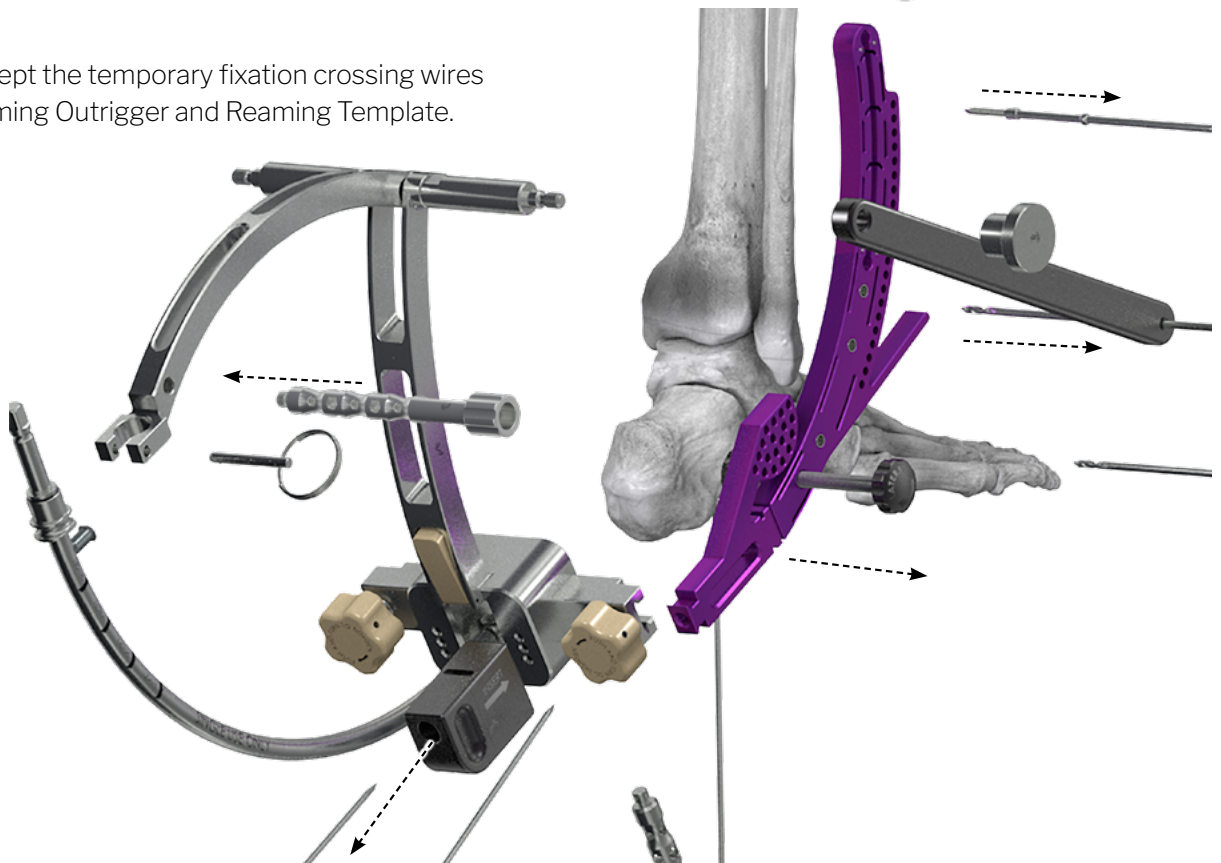

NAIL ASSEMBLY:

1. Ensure the compression screw in the nail is not visible in the bottom slot of the nail. If necessary, back the screw down into the nail using the provided hex driver.

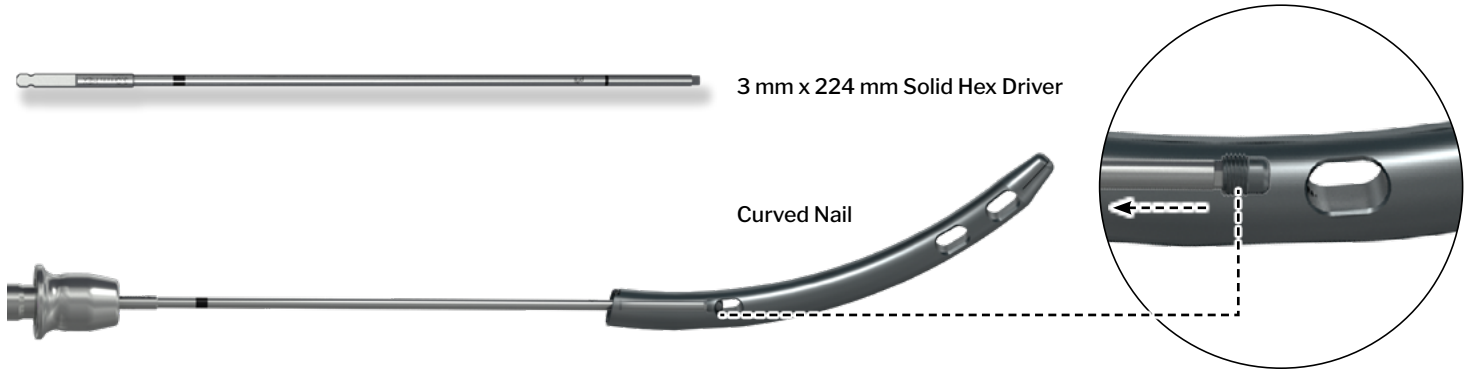

2. Attach the Hex Bolt Attachment to the Outrigger Mounting Bolt by sliding it together and drive the Outrigger Mounting Bolt into the top slot of the Nail Attachment Outrigger..

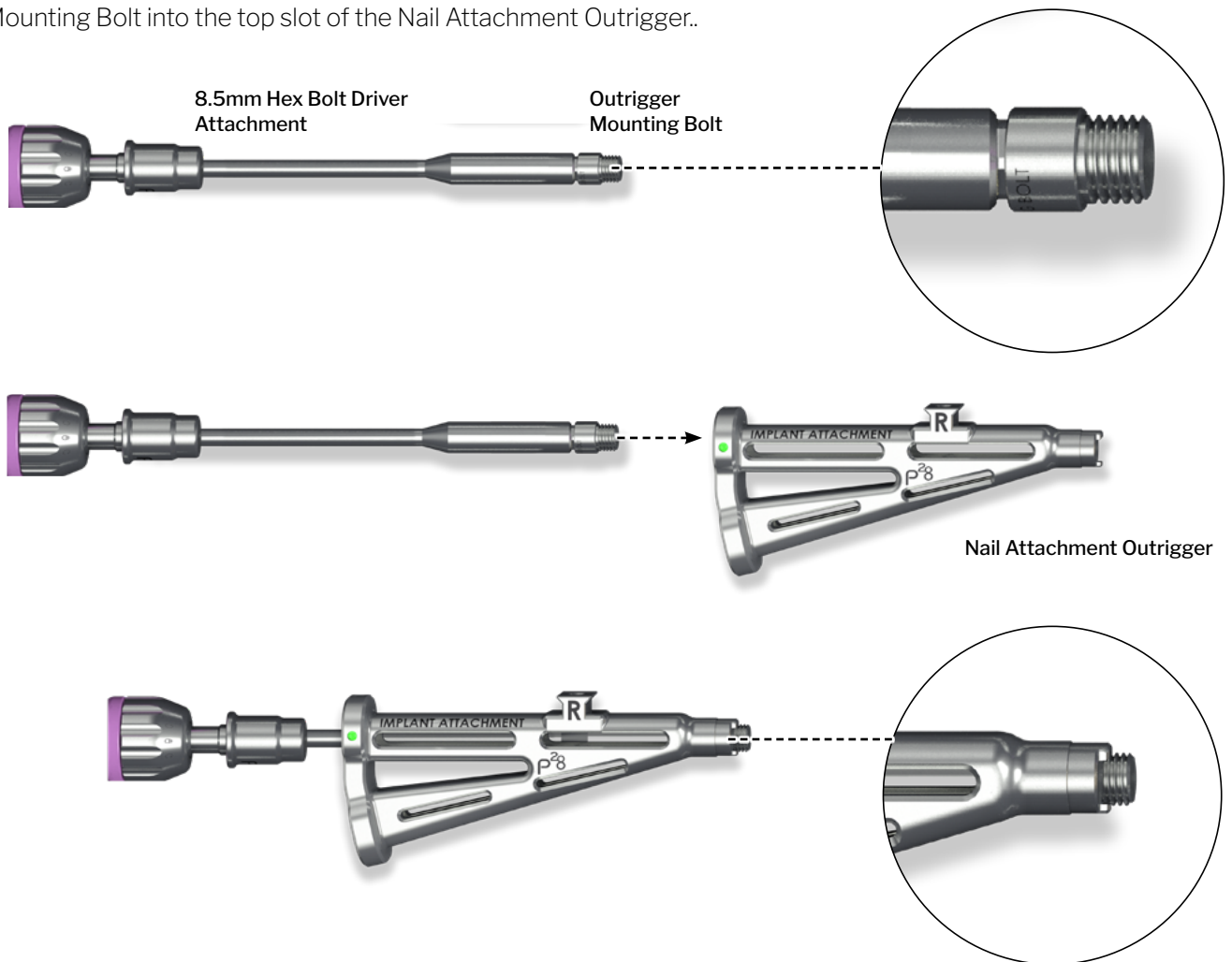

NAIL ASSEMBLY:

3. Attach the appropriately sized Nail to the implant Outrigger by threading the mounting bolt into it through the Nail Outrigger.



4. Attach the Nail Outrigger combo to the Nail Targeting Outrigger by sliding the dovetail together on the side corresponding to the patient laterality then push down and turn the knob clockwise to secure.

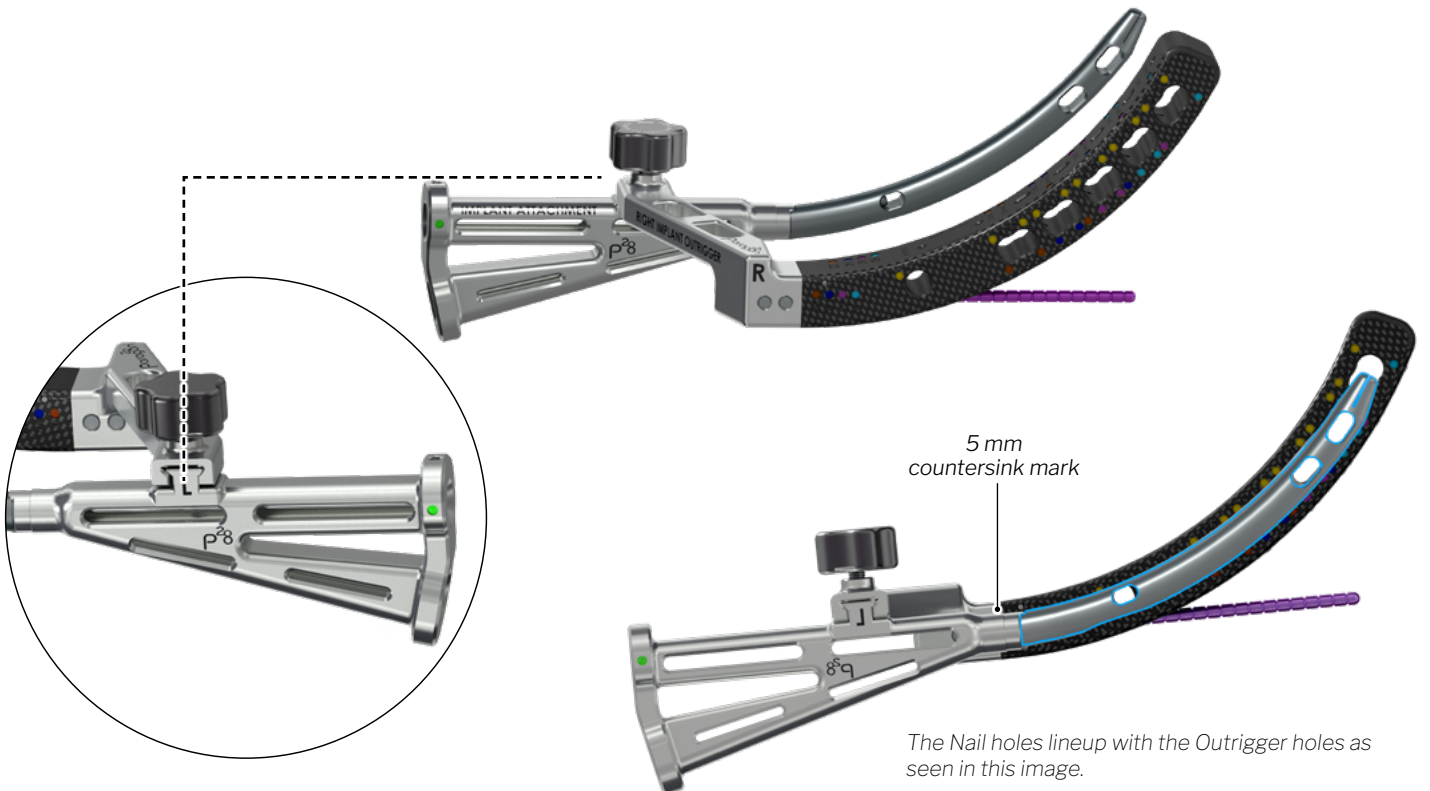
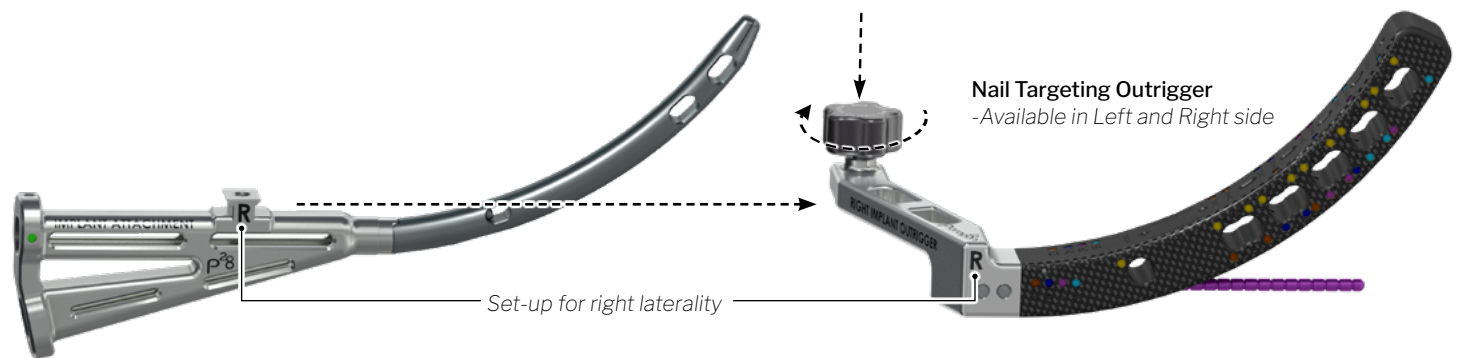

NAIL PLACEMENT:



Insert the Nail through the incision in the calcaneus and seat until the boss of the Outrigger is contacting the skin. Strike the end of the Outrigger in a controlled manner only with the provided hammer to insert the Nail.

DO NOT wiggle or twist the Nail during insertion as anatomy can shift given the Curved Nail geometry.

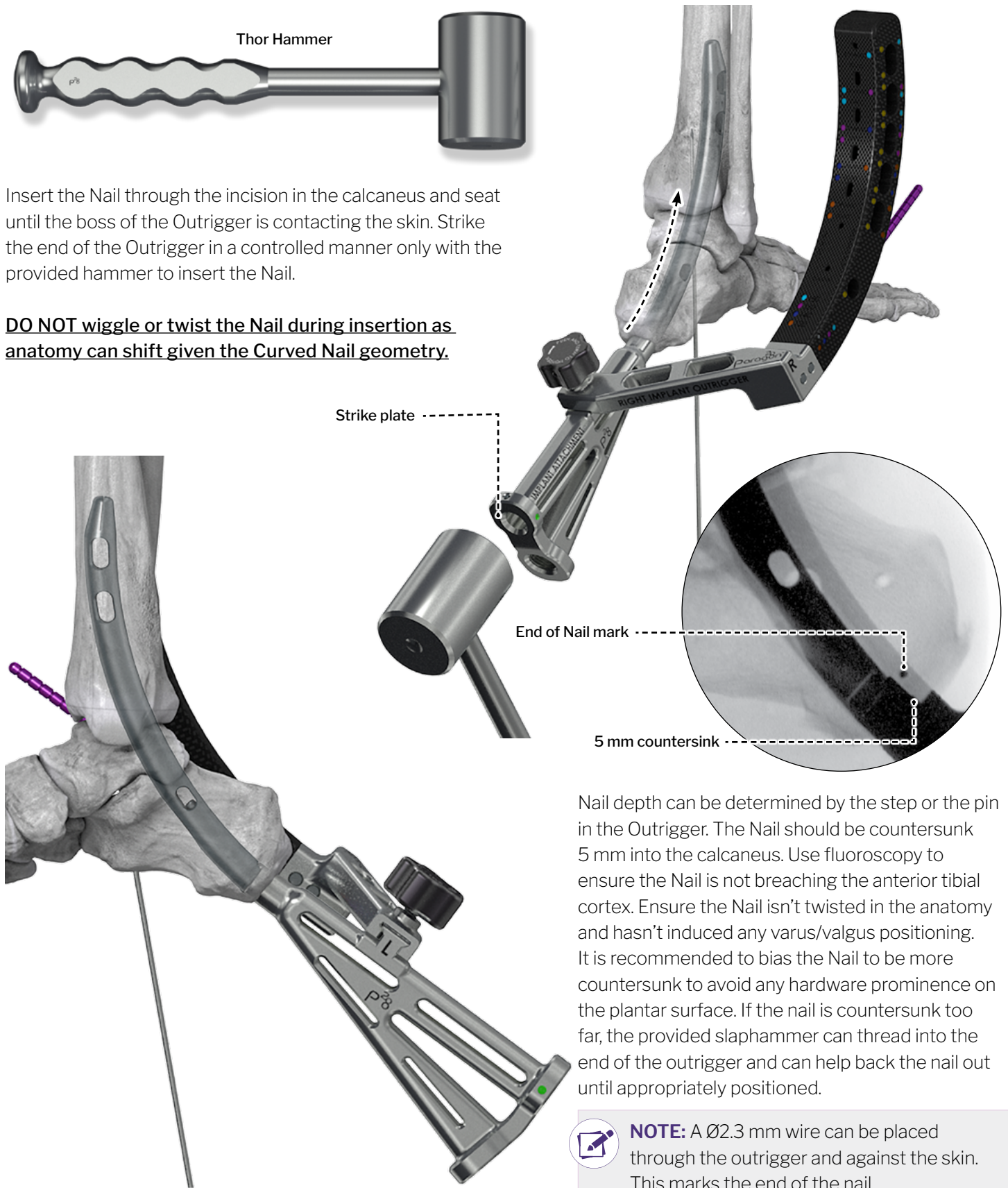

Nail depth can be determined by the step or the pin in the Outrigger. The Nail should be countersunk 5 mm into the calcaneus. Use fluoroscopy to ensure the Nail is not breaching the anterior tibial cortex. Ensure the Nail isn't twisted in the anatomy and hasn't induced any varus/valgus positioning. It is recommended to bias the Nail to be more countersunk to avoid any hardware prominence on the plantar surface. If the nail is countersunk too far, the provided slaphammer can thread into the end of the outrigger and can help back the nail out until appropriately positioned.

NOTE: A Ø2.3 mm wire can be placed through the outrigger and against the skin. This marks the end of the nail.

NAIL PLACEMENT - LATERAL TIBIAL PEGS:

Assemble the Lateral Peg Guides by threading the Lateral Drill Guide into the Lateral Peg Guide.

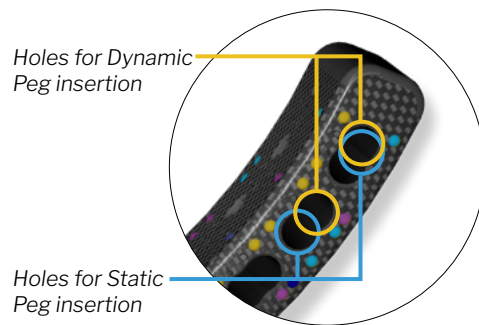
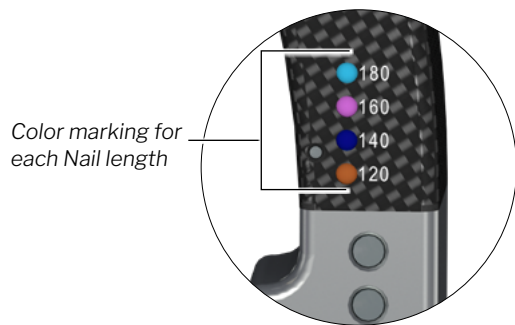
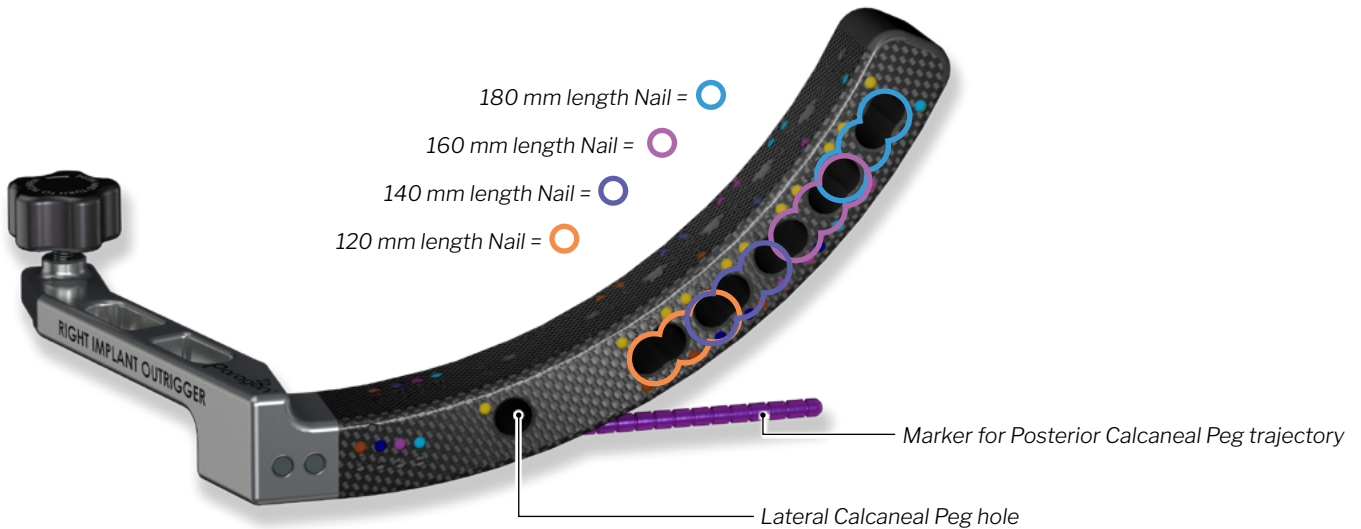

REFER TO THE CHECKLIST FOR PEG PLACEMENT:

- ✓ Assemble appropriate Drill and Peg Guide
- ✓ Place in appropriate hole in Outrigger
- ✓ Make a stab incision at the entry point
- ✓ Perform blunt dissection down to bone
- ✓ Drill bicortical with the appropriate Drill
- ✓ Measure depth (add 2 mm if measuring off the Drill)
- ✓ Remove Drill Guide and place Peg through Peg Guide
- ✓ Advance with appropriate Driver
- ✓ Confirm placement under fluoroscopy

NAIL PLACEMENT - LATERAL TIBIAL PEGS:

For the proximal peg, place one assembled Lateral Peg Guide into the dynamic screw location for the corresponding Nail length. For the distal peg, place another Lateral Peg Guide in either the static or dynamic screw location for the corresponding Nail length.

For a static Nail that allows for future weight-bearing compression with removal of the distal Tibia Threaded Peg, place the distal peg in the static position. For a weight-bearing compression Nail, place the distal peg in the dynamic position.



Dynamic

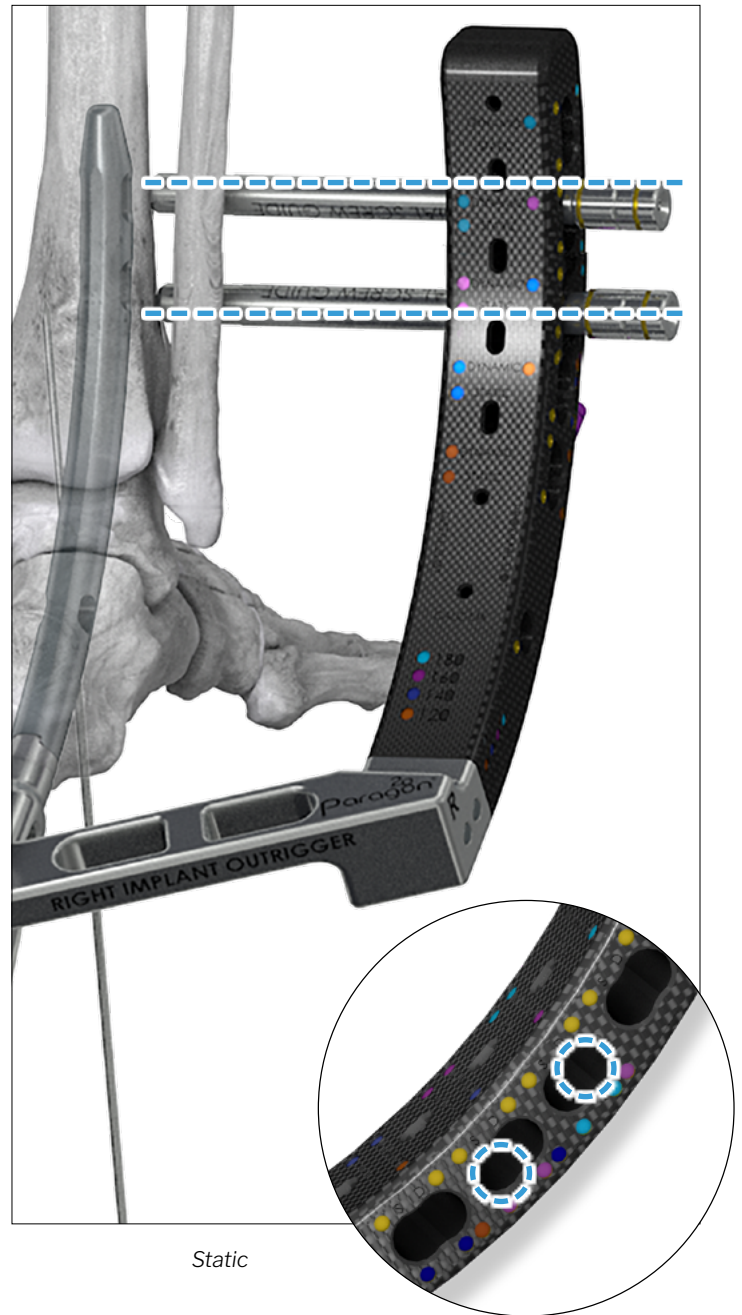

Static

NAIL PLACEMENT - LATERAL TIBIAL PEGS:



Solid Depth Gauge



Ø3.8 x 250 mm Solid Drill

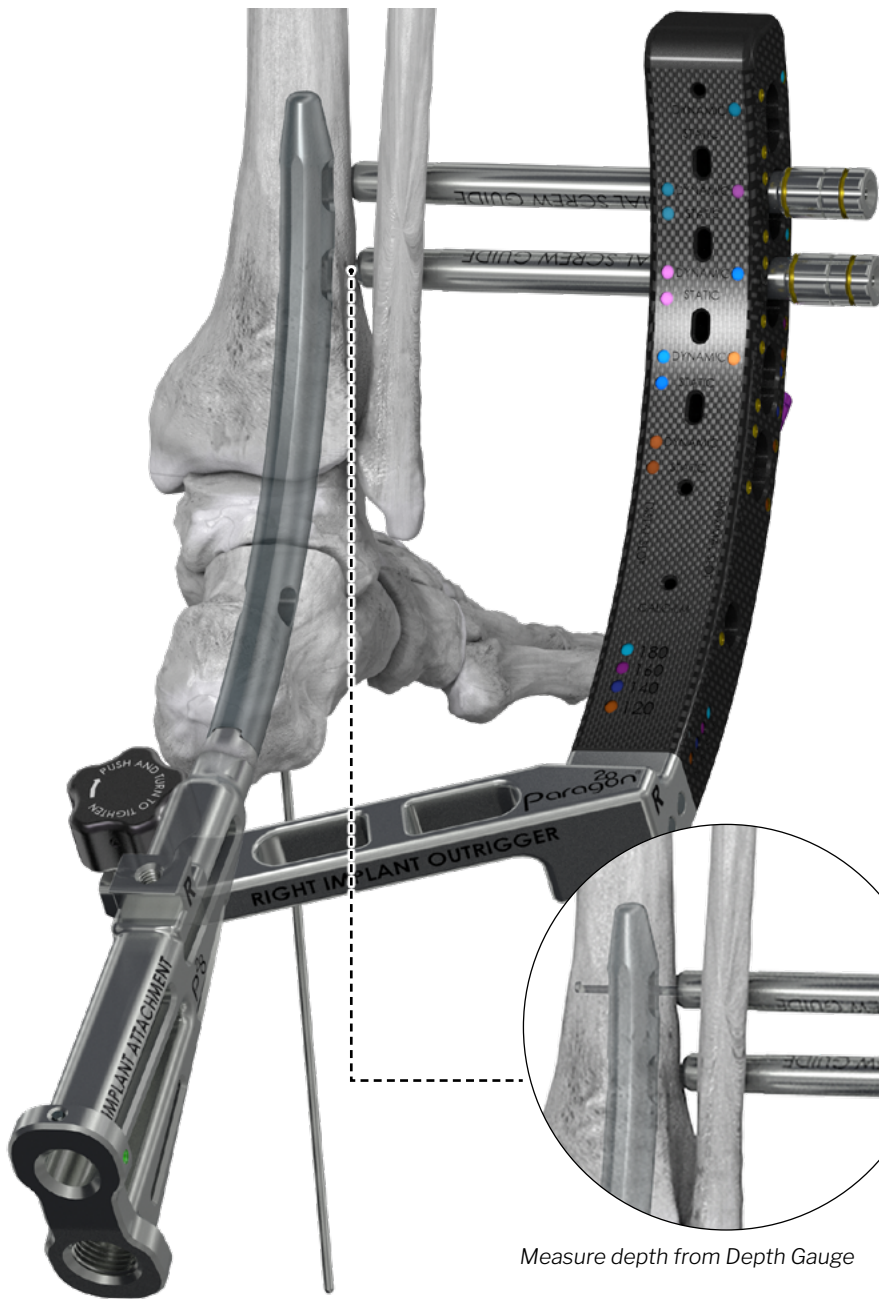

Follow steps listed on page 33 for Lateral Tibia Peg placement

If the guide is sitting on the Fibula, be sure to account for the width of the fibula when measuring the screw length.

Measure depth from Depth Gauge

Measure depth from Solid Drill

NAIL PLACEMENT - LATERAL TIBIAL PEGS:

Ratcheting Handle

TX-20 Driver

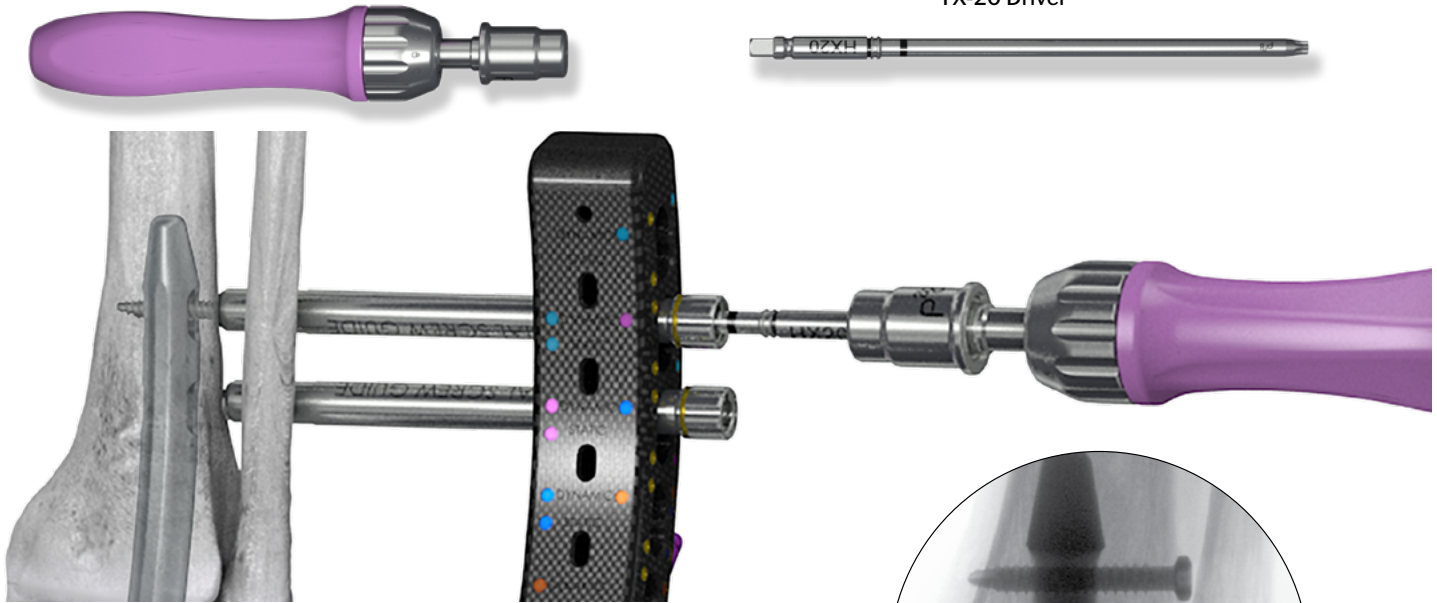

Repeat the previous steps to place the second Lateral Tibial Threaded Peg in the distal static or dynamic slot.

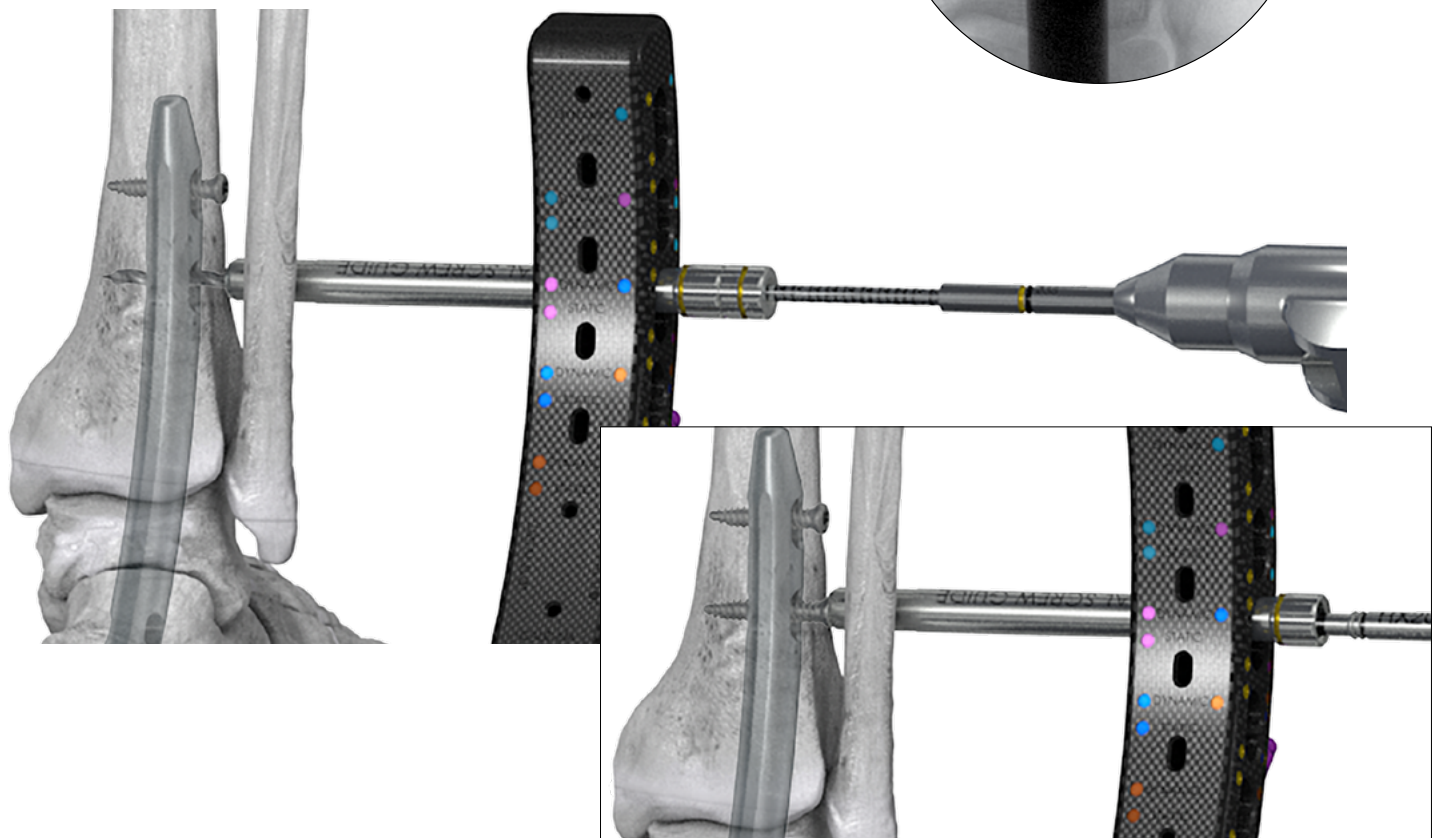

NAIL PLACEMENT - LATERAL CALCANEAL PEG:

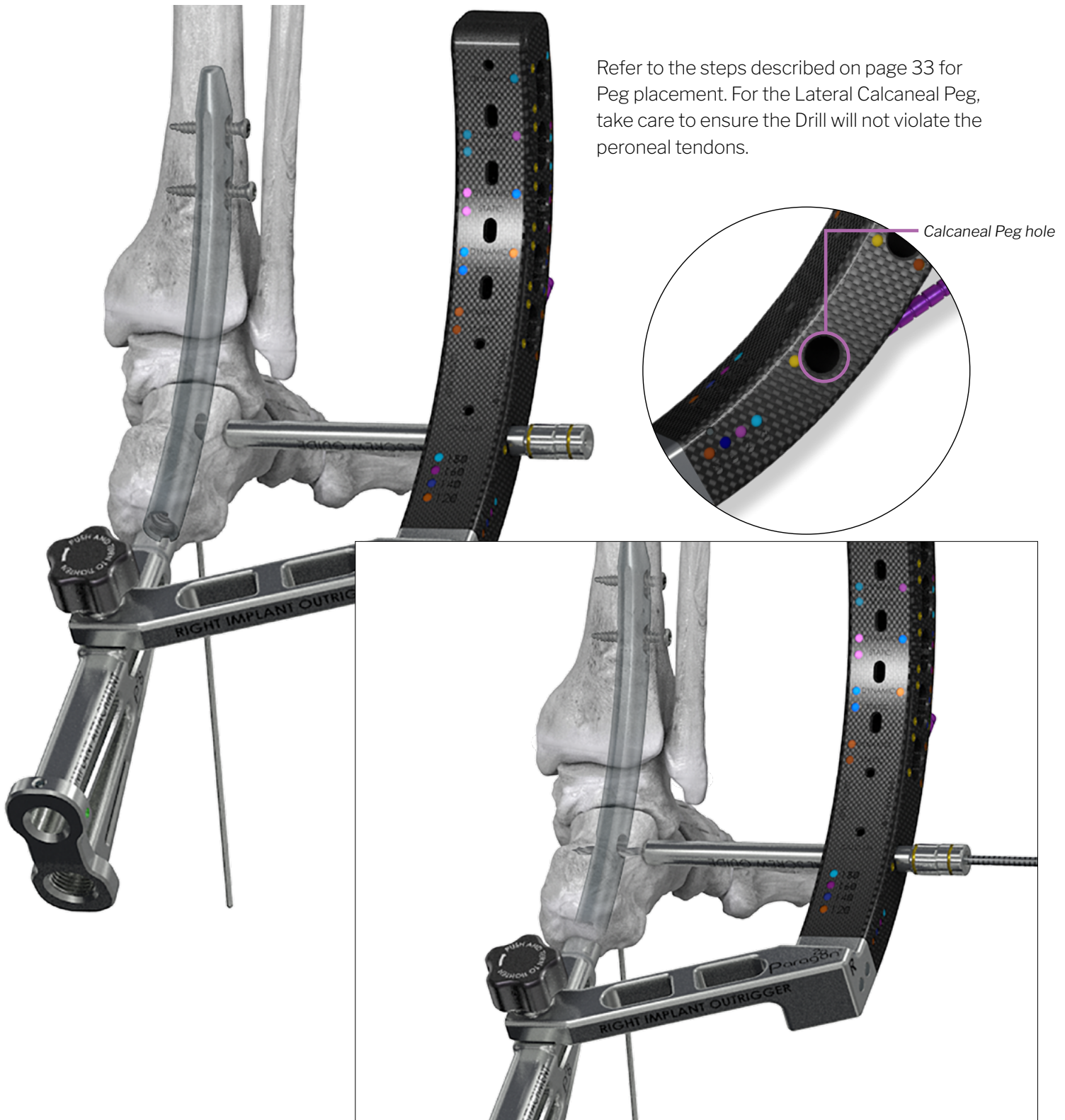

Use caution to ensure the drill does not plunge through the bone to protect structures on the medial side.

NAIL PLACEMENT - LATERAL CALCANEAL PEG:

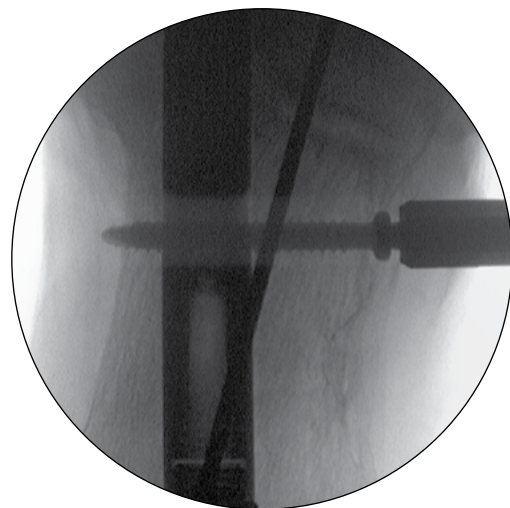
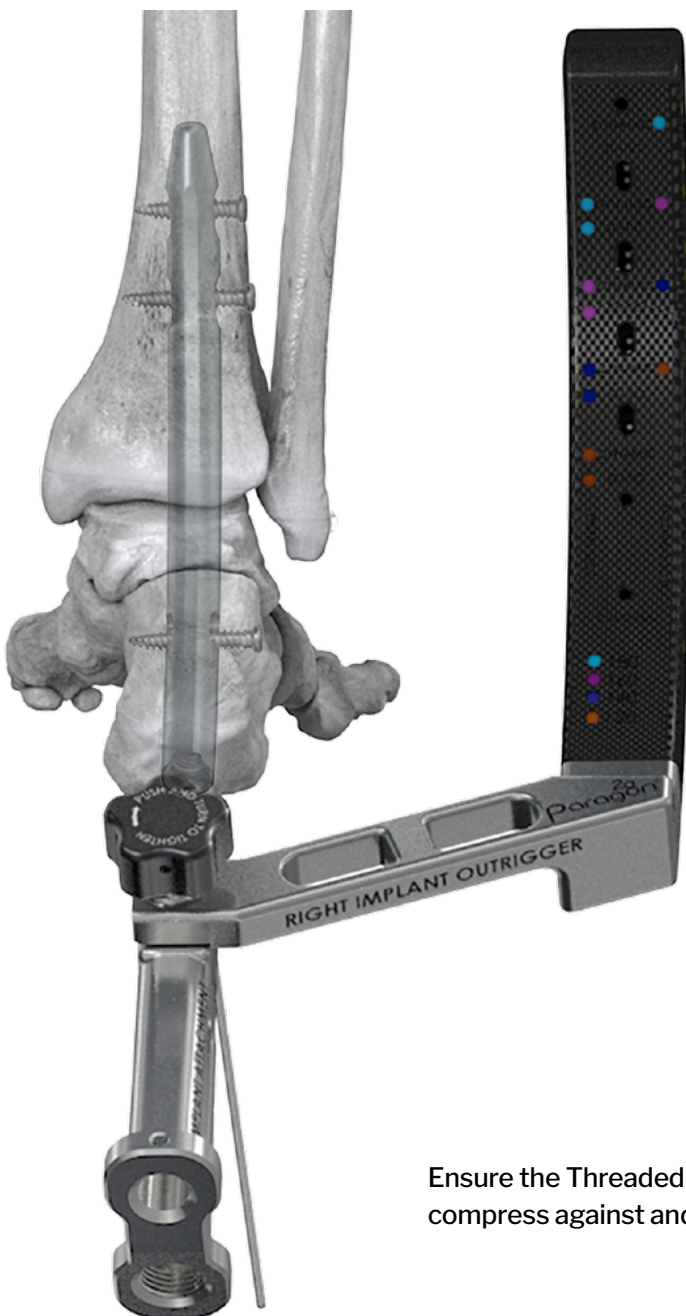

Ensure the Threaded Peg is bicortical using fluoroscopy. The peg is used to compress against and could migrate if not bicortical

NAIL PLACEMENT - INTERNAL COMPRESSION:

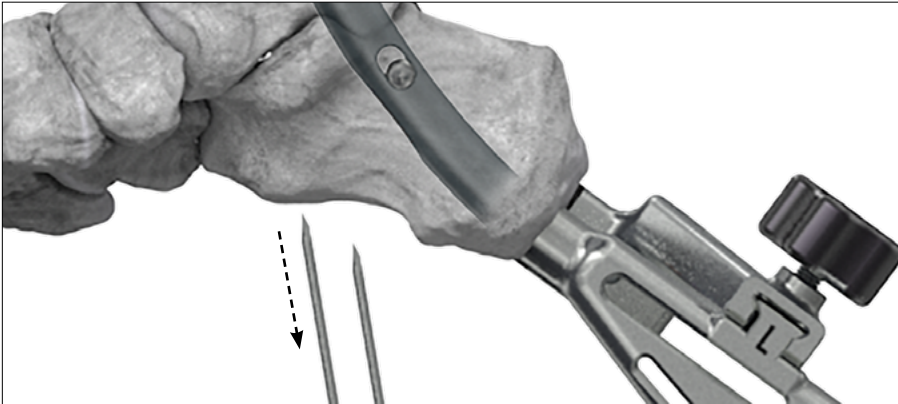

Remove any temporary fixation wires.

Torque Limiting Axial Handle



3 mm x 224 mm Solid Hex Driver

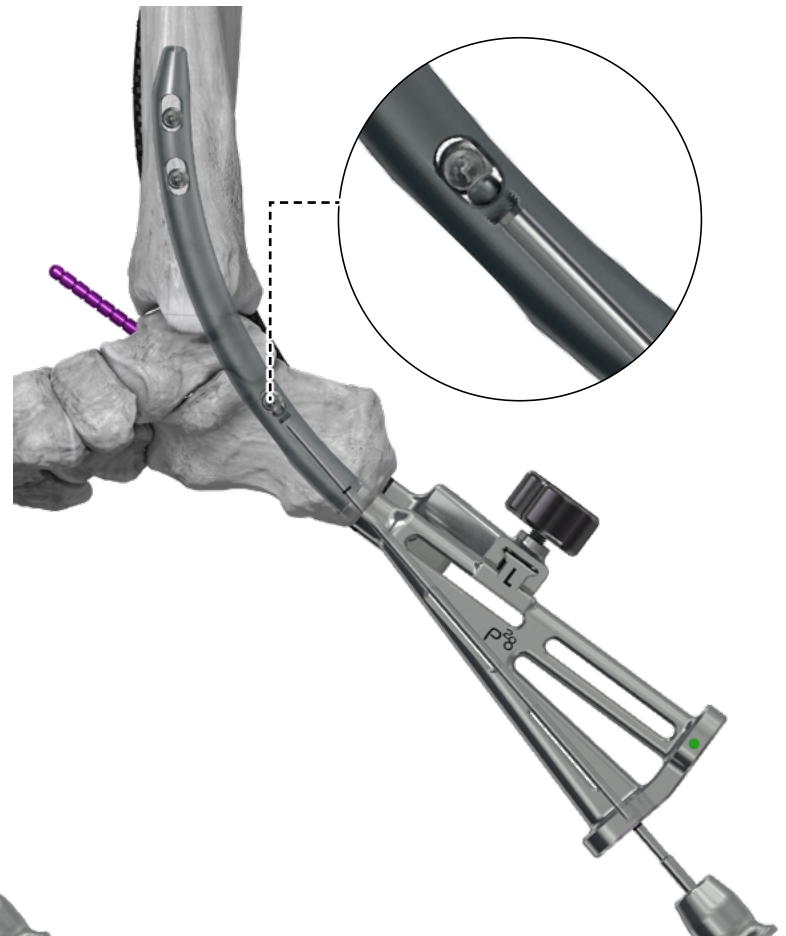
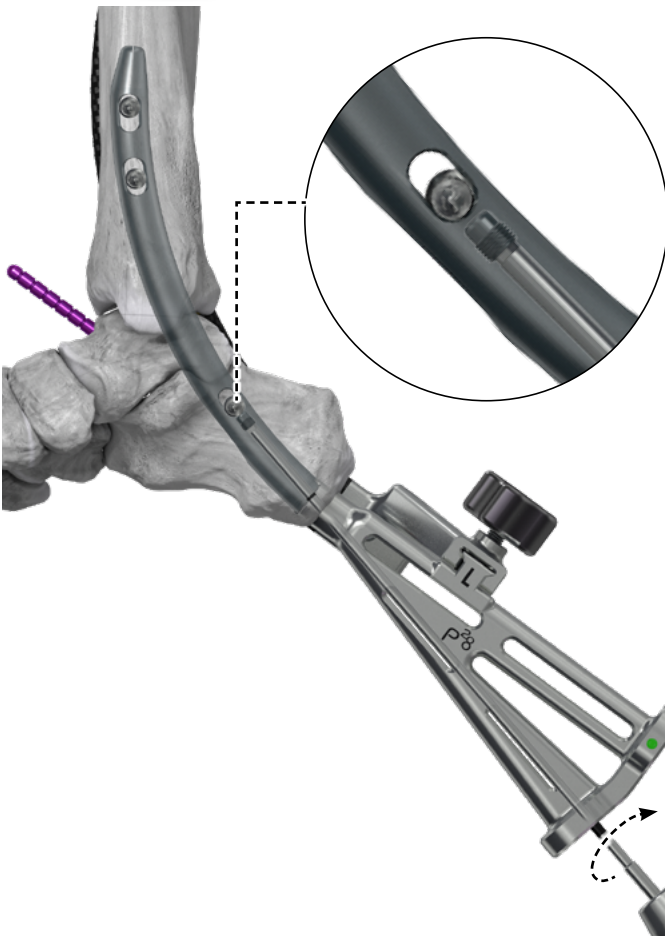

Use the provided Hex Driver and the torque limiting handle to compress the compression screw seated in the Nail. The driver will not be able to advance it further when the torque limit is reached.



NOTE: Do not use the other handles to avoid over compressing.

NAIL PLACEMENT - POSTERIOR CALCANEAL THREADED PEG: _____

Outrigger Posterior Drill Guide

Outrigger Posterior Peg Guide

Assembled Guide

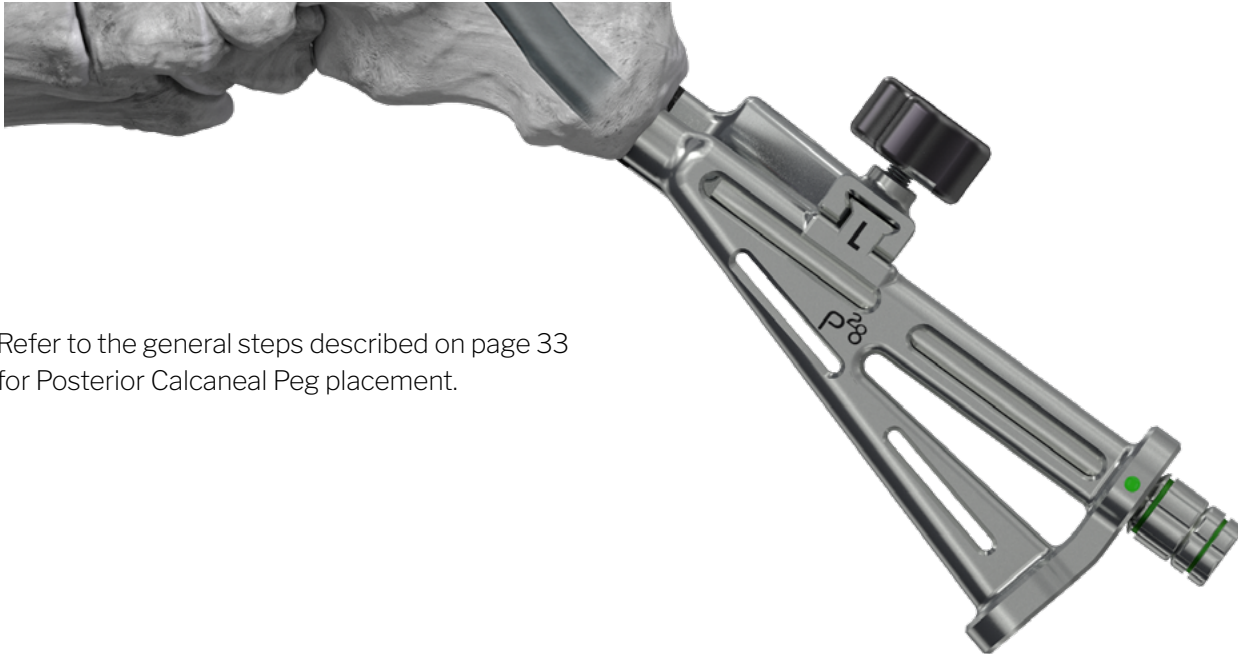

Refer to the general steps described on page 33 for Posterior Calcaneal Peg placement.



NAIL PLACEMENT - POSTERIOR CALCANEAL THREADED PEG: _____



The posterior calcaneal peg will thread in to the end of the Nail.



NOTE: Take care if placing this Threaded Peg under power as it will thread into the Nail and can torque the Driver if used.

Be sure the peg is fully threaded into the Nail before proceeding.

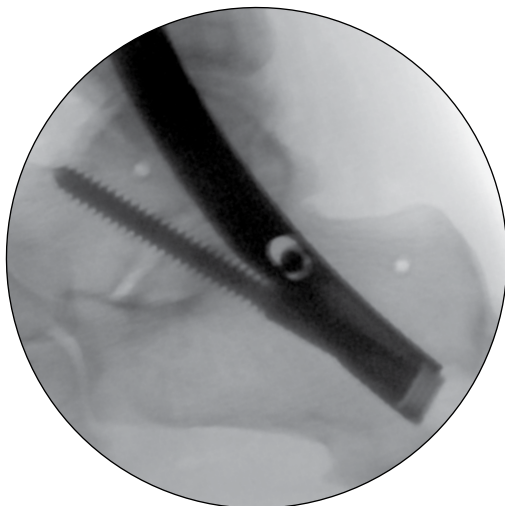

Verify the Threaded Peg length and placement under fluoroscopy.

NAIL PLACEMENT - END CAP PLACEMENT:

Verify Nail and Threaded Peg placement under multiple fluoroscopic views.

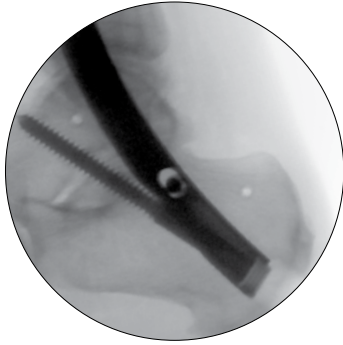

Medial view

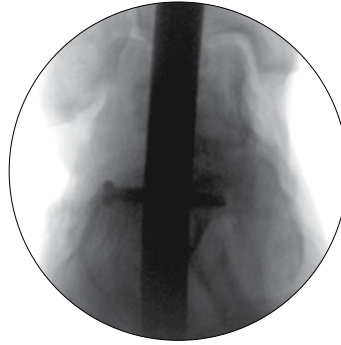

AP view

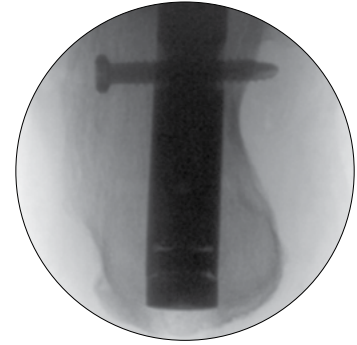

Calc-Axial view

Hex Bolt Driver Attachment and Outrigger Mounting Bolt



Using the Outrigger Mounting Bolt Driver and Handle, turn counterclockwise until the Outrigger is released from the Nail.

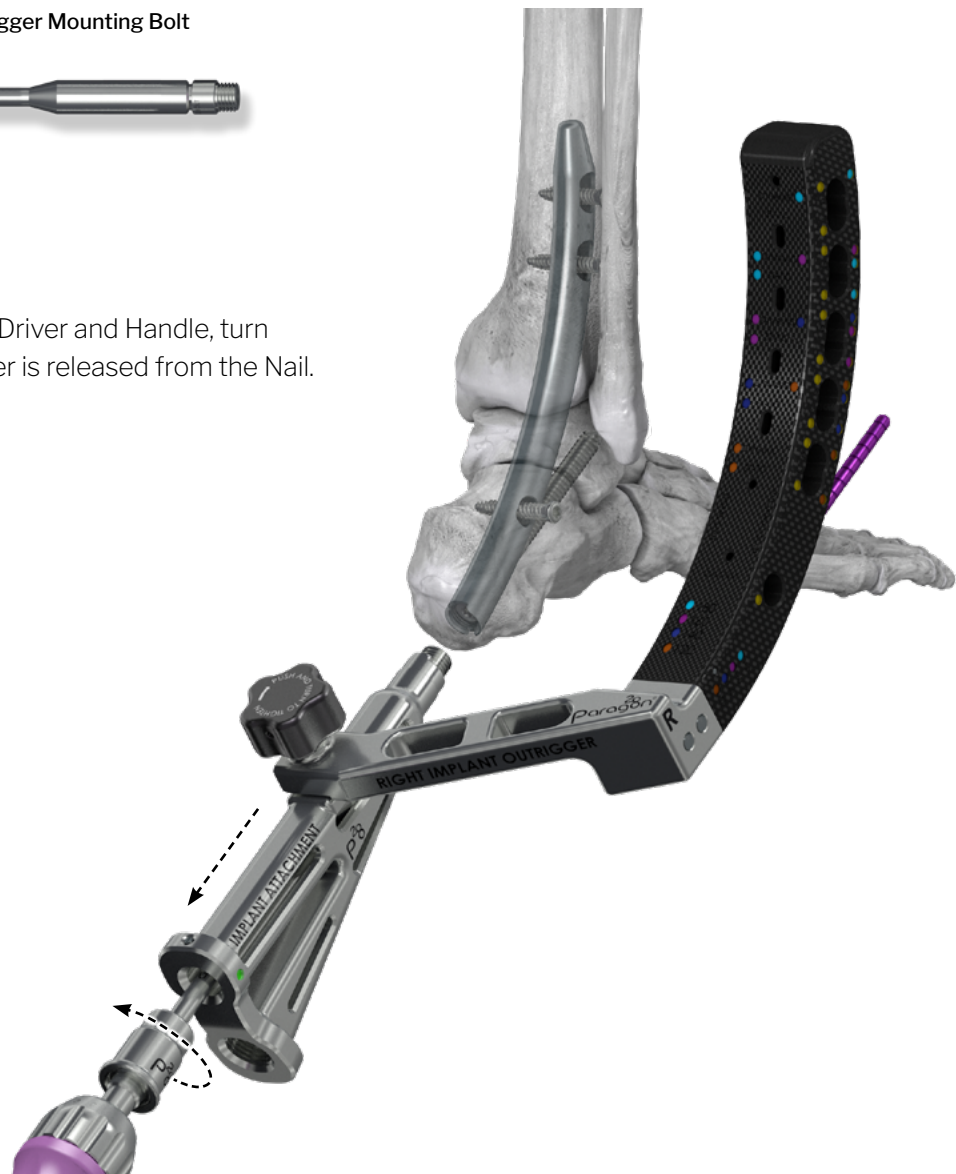

NAIL PLACEMENT - END CAP PLACEMENT:

Long Shouldered End Cap



Short Shouldered End Cap



Secure the selected End Cap to the Nail using the TX-25 Driver in a clockwise direction until the End Cap is secure. Bony in growth may occur if an end cap is not used, making implant removal more difficult. Use the appropriate length End Cap for how countersunk the nail is such that the End Cap is not prominent.

The End Cap may not look fully seated on lateral fluoroscopy, but that is due to the cut out in the Nail.

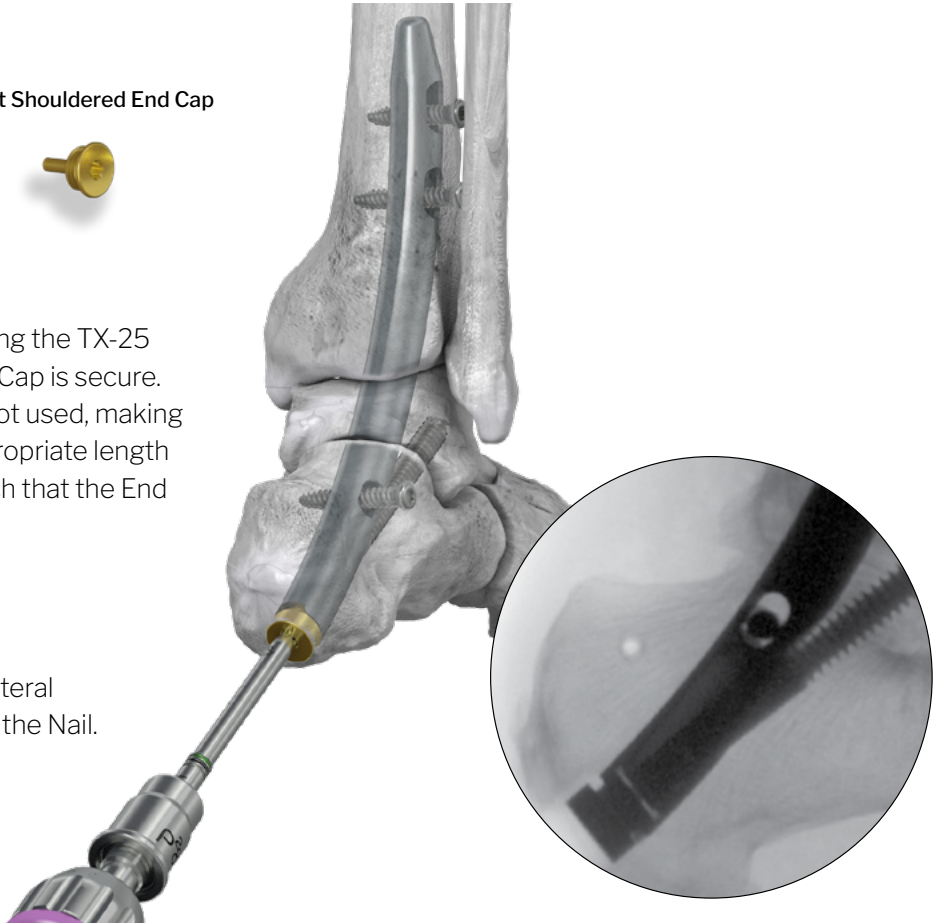

CLOSURE:



Proceed to incision closure or concomitant procedures at this time.

NAIL REMOVAL:

Attach the TX-25 Driver to the appropriate handle.

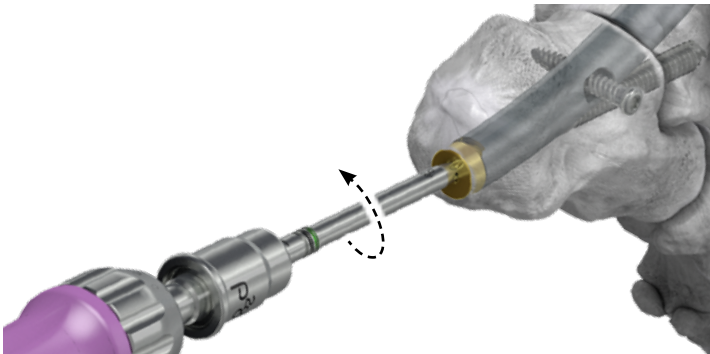

Using fluoroscopy, locate the calcaneal insertion point of the Nail, and make a small incision. If an end cap was used, insert the TX-25 Driver into the end cap and rotate counterclockwise to remove. Utilize the TX-25 Driver and Handle to remove the Posterior Calcaneal Threaded Peg that is seated in the Nail.

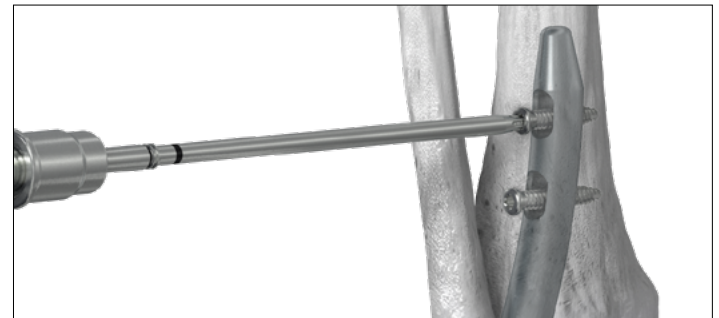
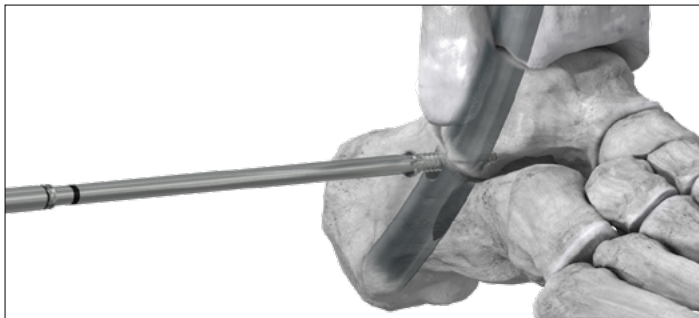

Using fluoroscopy, locate the calcaneal and Lateral Tibial Threaded Pegs. Make a small incision at each Threaded Peg location and insert the TX-20 Driver into the head of the Threaded Peg. Turn in a counterclockwise direction until each Threaded Peg is removed.

Confirm removal of all Threaded Pegs using fluoroscopy before attempting to remove the Nail.



Attach the Slap Hammer Construct to the Nail by rotating the explant attachment in a clockwise direction into the plantar portion of the Nail.

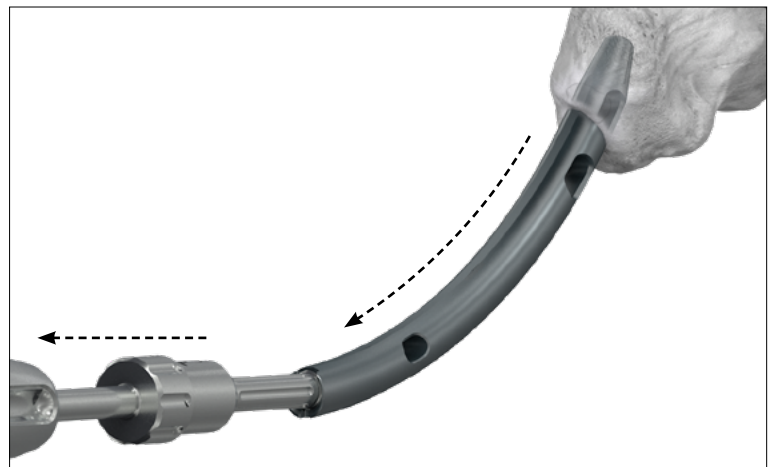

Use the sliding mechanism of the Slap Hammer to back the Nail out of the foot in an inferior direction until the Nail is removed.

INSTRUMENT CASE:

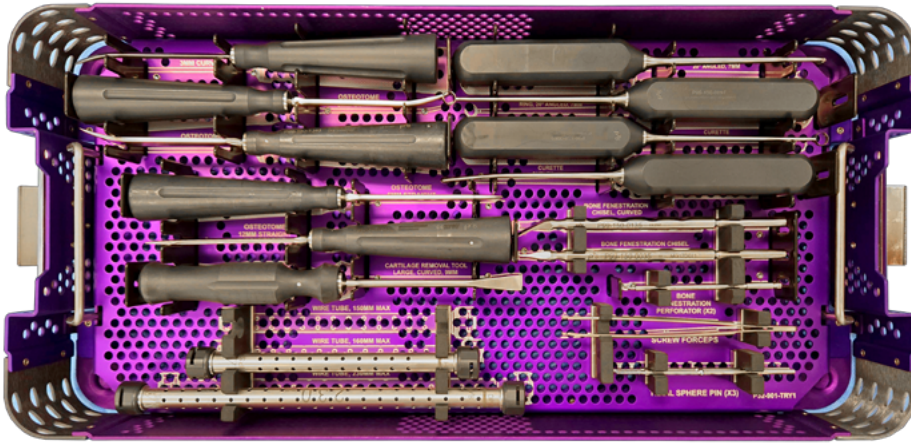

Curved Nail Instrument Tray
 Joint Preparation Instrumentation, K-wires, and Tibial Sphere Wires are located within this Tray.

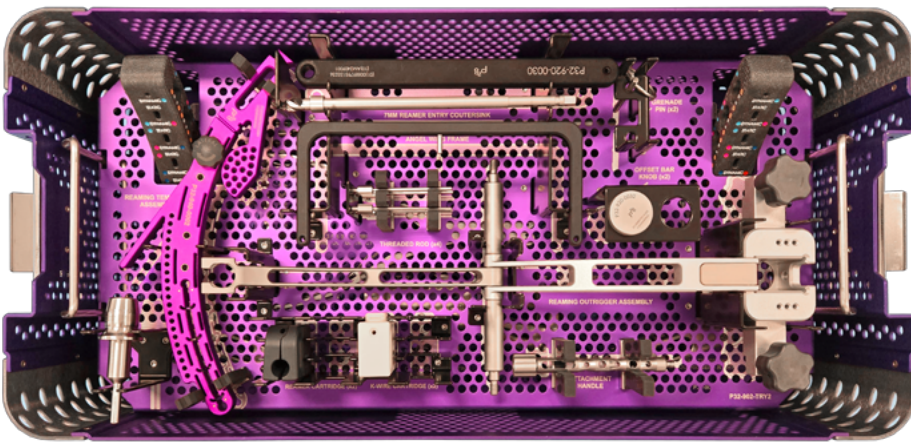

Curved Nail Instrument Tray
 Reaming Template Assembly, Reaming Outrigger Assembly, Handle, K-wire Cartridge, Reamer Cartridge, Angel Wing, Angel Wing Threaded Rods, Offset Bar, Offset Bar Knob, Grenade Pins, and Reamer Entry Countersink are located within this Tray.

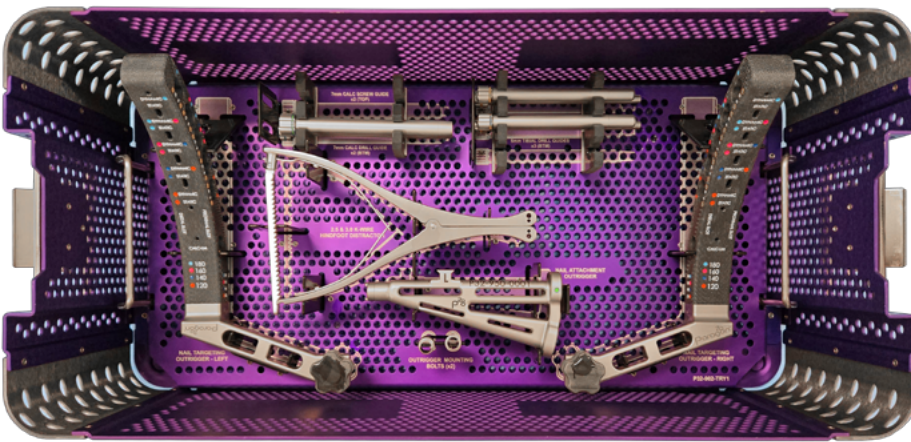

Curved Nail Instrument Tray
 Drill Guides, Hindfoot Distractor, Nail Attachment Outrigger, Nail Targeting Outrigger, and Outrigger Mounting Bolts are located at the bottom of this Tray.

INSTRUMENT CASE:

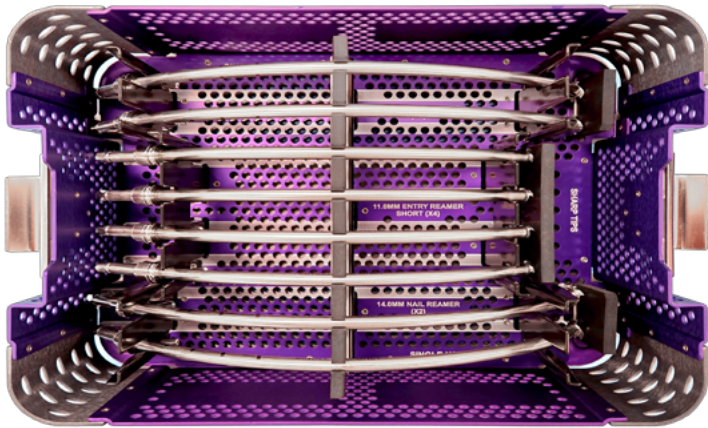

Curved Nail Reamer Tray

Curved Entry Reamers and Curved Reamers are located within this Tray.

Ø5.0 mm Caddy

Ø7.0 mm Caddy

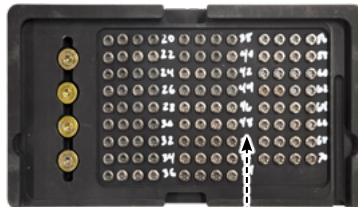

Curved Nail Threaded Peg Caddy

Ø5.0 mm and Ø7.0 mm Threaded Pegs and End Caps are located within these Caddies.

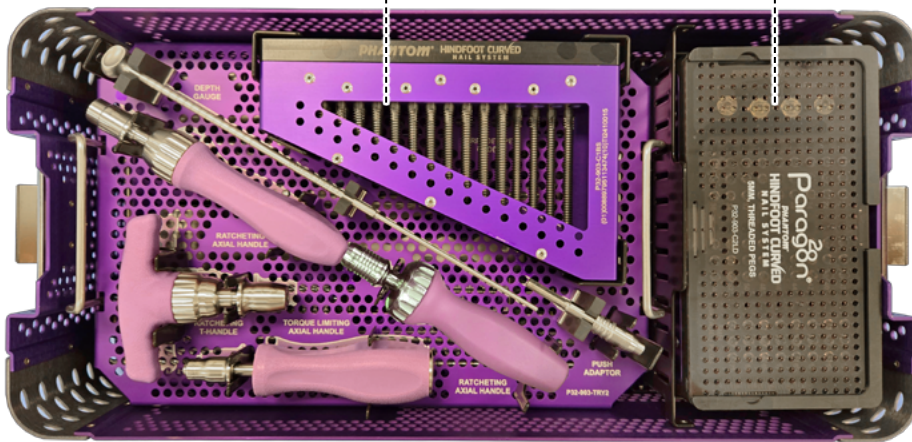

Curved Nail Instrument Tray

Handles, Depth Gauge, Square Adaptor, and Ø7.0 mm Threaded Pegs are located within this Tray.

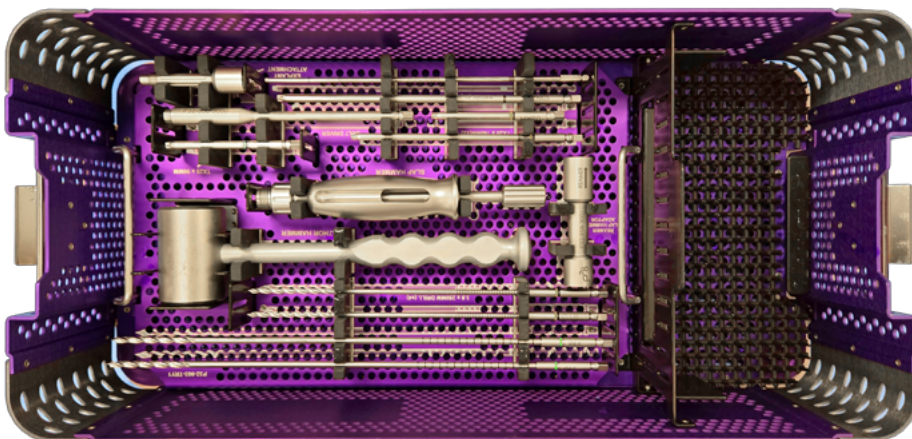

Curved Nail Instrument Tray

Drills, Drivers, Thor Hammer, Slap Hammer, and Explant Attachment are located at the bottom of this Tray.

IMPLANT CASE: _____

Part #	Description	Use
P32-270-125[2,4,6,8]-S	Ø12.5 mm Nail	Single-use
P32-270-140[2,4,6,8]-S	Ø14.0 mm Nail	Single-use
P32-959-STRQ-S	Torque Limiting Adapter	Single-use
P32-959-TUBE-S	Irrigation Tube	Single-use
P99-106-6005-S	Ø6.0 x 55 mm Barrel Burr	Single-use
P99-107-6005-S	Ø6.0 x 55 mm Oval Burr	Single-use

INSTRUMENT CASE: _____

Part #	Description	Use
P99-192-2323	Ø2.3 x 230 mm K-wire	Single-use
P32-951-2720	Ø2.7 x 20 mm Tibial Sphere Pin	Single-use
P32-951-3016	Ø3.0 x 160 mm Fixation Pin	Single-use
P99-100-2010	Bone Fenestration Perforator	Reusable
P99-150-0001	Screw Forceps	Reusable
P99-150-0035	Bone Fenestration Chisel	Reusable
P99-150-0055	Cartilage Removal Tool	Reusable
P99-150-009[4-7]	Curettes	Reusable
P99-150-0135	Bone Fenestration Chisel, Curved	Reusable
P99-150-124[1,3]	Straight Osteotomes	Reusable
P99-150-134[0,1,3]	Curved Osteotomes	Reusable
P32-920-0000	Reaming Outrigger Assembly	Reusable
P32-920-0030	Offset Bar	Reusable
P32-920-0032	Offset Bar Knob	Reusable
P32-920-0040	Grenade Pin	Reusable
P32-920-0050	Angel Wing Frame	Reusable
P32-920-0051	Angle Wing Threaded Rod	Reusable
P32-920-0060	Attachment Handle	Reusable
P32-940-0002	Reaming Template Assembly	Reusable
P32-950-0001	Nail Attachment Outrigger	Reusable
P32-950-0002	Outrigger Mounting Bolt	Reusable
P32-950-0003	Ø5.0 mm Outrigger Tibial Drill Guide	Reusable
P32-950-0005	Ø5.0 mm Outrigger Tibial Screw Guide	Reusable
P32-950-0008	Ø7.0 mm Outrigger Calcaneal Drill Guide	Reusable
P32-950-0009	Ø7.0 mm Outrigger Calcaneal Screw Guide	Reusable

INSTRUMENT CASE: _____

Part #	Description	Use
P32-950-0100-[L/R]	Nail Targeting Outrigger	Reusable
P32-960-0001	Ø7.0 mm Reamer Entry Countersink	Reusable
P32-970-0001	Reamer Cartridge	Reusable
P32-970-0002	K-wire Cartridge	Reusable
P99-150-0010	Hindfoot Distractor	Reusable
P32-959-0110	Ø11.0 mm Entry Reamer	Single-use
P32-959-0145	Ø12.5 mm Nail Reamer	Single-use
P32-959-0160	Ø14.0 mm Nail Reamer	Single-use
P32-959-CAPS	Reamer Caps	Single-use
P32-102-000[1,5]	Shouldered End Cap	Single-use
P32-450-0[2-7][0,2,4,6,8]F	Ø5.0 mm Threaded Peg	Single-use
P32-770-[0,1][4-9][0,5]F	Ø7.0 mm Threaded Peg	Single-use
P32-950-9000	Bolt Driver Attachment	Reusable
P32-957-0001	Depth Gauge	Reusable
P32-958-0001	Explant Attachment	Reusable
P32-958-3001	Reamer Slap Hammer Adapter	Reusable
P99-000-316M	Medium Axial Ratcheting Handle	Reusable
P99-000-316P	3/16" Sq. Push Adaptor	Reusable
P99-000-316T	3/16" Sq. Adaptor T-Handle	Reusable
P99-000-TQ40	Torque Limiting Axial Handle	Reusable
P99-000-014A	1/4" Square/Jacobs Adapter	Reusable
P99-100-3825	Ø3.8 x 250 mm Drill	Single-use
P99-100-4634	Ø4.6 x 340 mm Drill	Single-use
P99-150-2001	Thor Hammer	Reusable
P99-150-2002	Slap Hammer	Reusable
P99-191-PC15-224	Ø3.0 mm x 224 mm Driver	Reusable
P99-191-TX20-09	TX-20 x 90 mm Driver	Reusable
P99-191-TX20-16	TX-20 x 160 mm Driver	Reusable
P99-191-TX25-09	TX-25 x 90 mm Driver	Reusable

Indications, Contraindications and Warnings

Refer to www.paragon28.com/ifus for the complete and most current instructions for use document.

MRI Safety Information



A patient with the Paragon 28® Phantom® Hindfoot TTC/TC Nail System may be safely scanned under the following conditions. Failure to follow these conditions may result in injury to the patient.

Name/Identification of device	Paragon 28® Phantom® Hindfoot TTC/TC Nail System
Nominal value(s) of Static Magnetic Field [T]	1.5 T or 3 T
Maximum Spatial Field Gradient [T/m and gauss/cm]	30 T/m (3000 gauss/cm)
RF Excitation	Circularly Polarized (CP)
RF Transmit Coil Type	Whole body transmit coil, Head RF transmit-receive coil
Maximum Whole Body SAW [W/kg]	2.0 W/kg (Normal Operating Mode)
Limits on Scan Duration	All anatomical regions can be safely scanned under the following conditions:
	1.0 W/kg whole body average SAR for 40 minutes of continuous RF (a sequence or back to back series/scan without breaks) with a 20 minute cooling period for an hour long scanning session
	Scanning of the knees and all anatomy superior to the knees can be safely scanned under the following conditions: 2.0 W/kg whole body average SAR for 60 minutes of continuous RF (a sequence or back to back series/scan without breaks)
If information about a specific parameter is not included, there are no conditions associated with that parameter.	



PHANTOM[®] HINDFOOT CURVED NAIL SYSTEM

SURGICAL TECHNIQUE GUIDE

Phantom[®] Hindfoot Curved Nail System

P32-STG-0001 Rev B [2026-03-10]

© Copyright 2025-2026 Zimmer Biomet[®]. All rights reserved.
Patents: www.paragon28.com/patents

All content herein is protected by copyright, trademarks and other intellectual property rights, as applicable, owned by or licensed to Zimmer Biomet or its affiliates unless otherwise indicated, and must not be redistributed, duplicated or disclosed, in whole or in part, without the express written consent of Zimmer Biomet.



www.Paragon28.com

Paragon 28[®], Inc.
14445 Grasslands Dr.
Englewood, CO 80112 USA
(855) 786-2828 📞

Disclaimer:

The purpose of the Phantom[®] Hindfoot Curved Nail System Surgical Technique Guide is to demonstrate the optionality and functionality of the Phantom[®] Hindfoot Curved Nail System. Although variations in placement and use of the Phantom[®] Hindfoot Curved Nail System can be performed, the fixation options demonstrated in this technique were chosen to demonstrate the functionality of the system and for simplicity of explanation. Other uses for the Phantom[®] Hindfoot Curved Nail System can be employed, appropriate for the size of the device. Federal law (U.S.A.) restricts this device to sale and use by, or on order of, a physician