

SURGICAL TECHNIQUE GUIDE:

BONE GRAFT HARVESTING

Exclusively foot & ankle **20**
Paragon[®]

BONE  **GRAFT**[™]
HARVEST SYSTEM

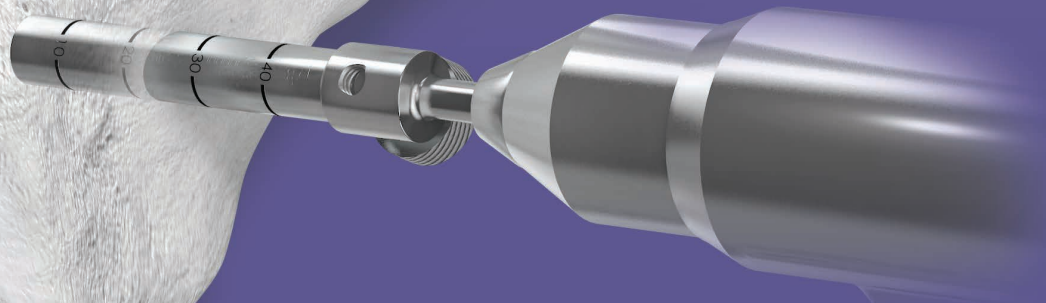

GORILLA[®]
R3CON PLATING SYSTEM

SYSTEM OVERVIEW

Autogenous bone graft can be used in primary and revision foot and ankle surgery. Autogenous bone provides osteogenic, osteoinductive and osteoconductive properties to the surgical site to aid in healing. Common harvest sites in the foot and ankle include the calcaneus, distal tibia and proximal tibia. Paragon 28® has developed a Bone Graft Harvester to allow for harvest of cancellous bone to augment foot and ankle surgical procedures. The Bone Graft Harvester is available in three diameters (6 mm, 8 mm and 10 mm) to allow the surgeon versatility in size depending on amount of bone graft needed and harvest site selected.

The Paragon 28® Bone Graft Harvester is designed for quick retrieval of morselized autogenous bone. A removable, reusable door attaches to the trephine to provide access to the harvested bone to facilitate recovery.

To increase bone volume, the harvested autogenous bone can be combined with demineralized bone matrix (DBM), allogenic cancellous bone chips, PRESERVE™ structural bone wedges or other sources of allogenic bone.

INSTRUMENTATION

Bone Graft Harvester



6 mm



8 mm



10 mm

- Bone Graft Harvester available in three sizes developed for common foot and ankle surgical applications
- Comprised of a trephine and door
- Depth markings present on trephine

Door

- The reusable door is designed for easy access to morselized bone graft via the twist knob



Trephine

- The single-use trephine interfaces with the door to provide a sharp cutting surface as well as an AO connection for attaching to power equipment



2.3 mm x 150 mm K-wire



- Available for use if a pilot hole is desired prior to using the Bone Graft Harvester

SURGICAL TECHNIQUE GUIDE:

BONE GRAFT HARVESTING - CALCANEUS

INCISION/EXPOSURE

The patient is placed supine with an ipsilateral hip bump or in a lateral decubitus position. Fluoroscopy can be used to facilitate incision placement. A small incision is made over the lateral aspect of the calcaneus, posterior and inferior to the peroneal tendons and sural nerve. Incision length should be slightly longer than the diameter of bone graft harvester to be used.

The incision is continued to the lateral wall of the calcaneus using blunt dissection. Care should be taken to protect branches of the sural nerve.



BONE GRAFT HARVESTER SELECTION & ASSEMBLY

Retrieve the selected bone graft harvester. For the calcaneus, a 6 mm or 8 mm bone graft harvester is recommended.

Assemble the bone graft harvester by retrieving the trephine portion of the bone graft harvester. The door size corresponding to the trephine size of the bone graft harvester is retrieved. Connect the door of the bone graft harvester to the trephine by inserting the female portion of the door under the "tab" male portion of the trephine.

Insert the thumb screw into the hole in the trephine and turn in a clockwise direction until the door is secured to the trephine.

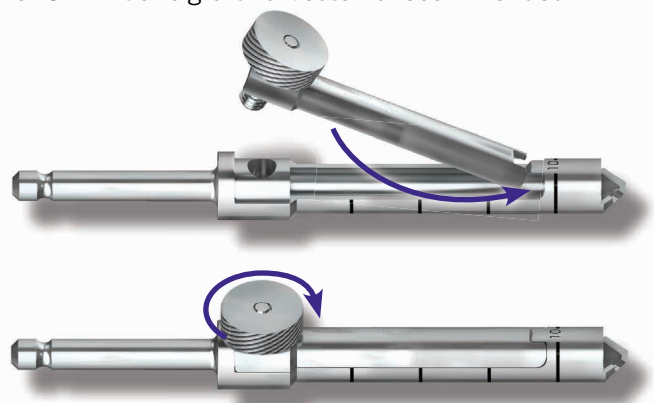

CANCELLOUS BONE HARVEST

Retraction is recommended during bone graft harvesting to avoid injury to the nearby structures and obtain visualization of the lateral wall of the calcaneus.

OPTIONAL: A 2.3 mm K-wire is provided to create a pilot hole at the desired entry point for the bone graft harvester. Drive the 2.3 mm K-wire past the near cortex to create the pilot hole.

Place the tip of the bone graft harvester into the pilot hole or at the desired starting point for bone graft harvester entry.



SURGICAL TECHNIQUE GUIDE:

BONE GRAFT HARVESTING - CALCANEUS

CANCELLOUS BONE HARVEST

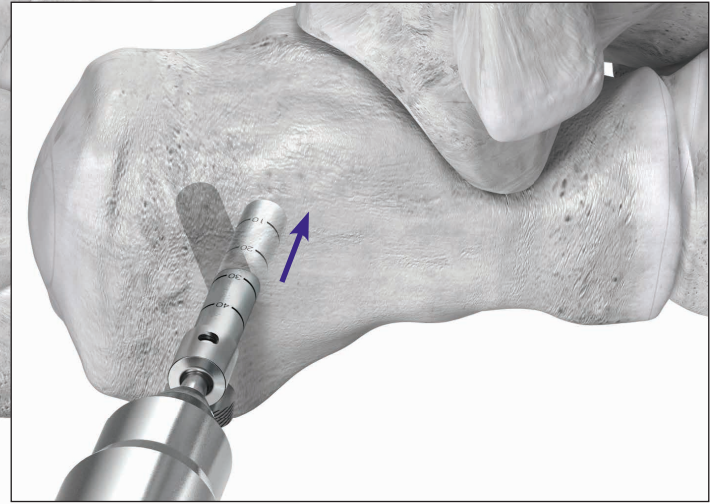
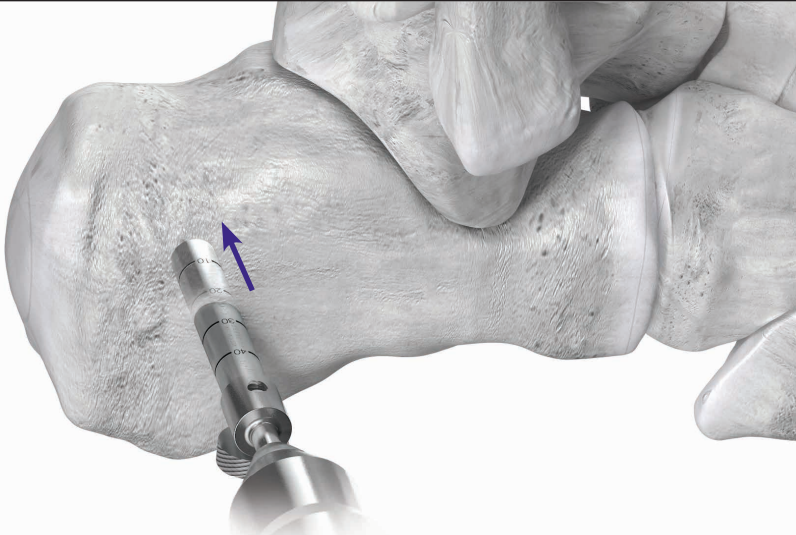

Contact the tip of the bone graft harvester to bone prior to applying power to the device. Under power, begin advancing the bone graft harvester into the cortical bone entry point. Advance the instrument to the desired depth and remove through the entry point.

NOTE: Additional bone graft may be harvested from the original bone graft harvester hole by re-directing the trephine 45° outward in a circular pattern. Approximately 3 passes of the bone graft harvester can be made before removal of morselized bone from the bone graft harvester is necessary.

REMOVAL OF MORSELIZED BONE GRAFT FROM BONE GRAFT HARVESTER

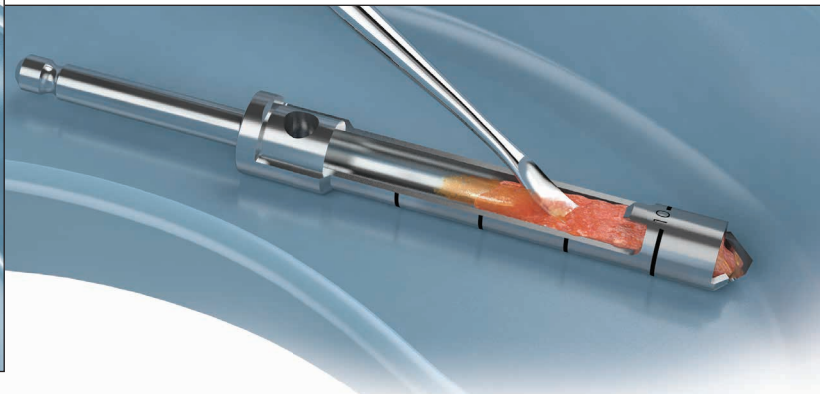
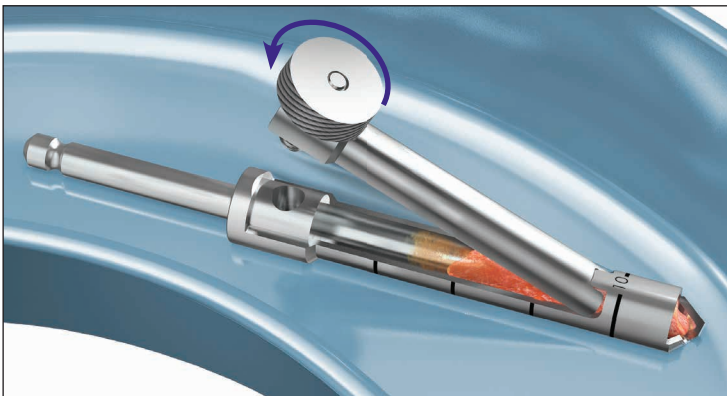

Over a sterile basin, twist the thumbscrew on the door in a counterclockwise direction. When disengaged from the trephine, pull the door off by separating the female portion of the door from the male portion of the trephine. Set the door aside for re-processing.

Using a freer elevator or a K-wire, remove the morselized bone graft from trephine and collect in a basin for later use or for mixing with allograft, if necessary.

OPTIONAL: The donor site in the calcaneus can be back-filled with allograft, per surgeon preference.

CLOSURE

Proceed to incision closure or concomitant procedures at this time.

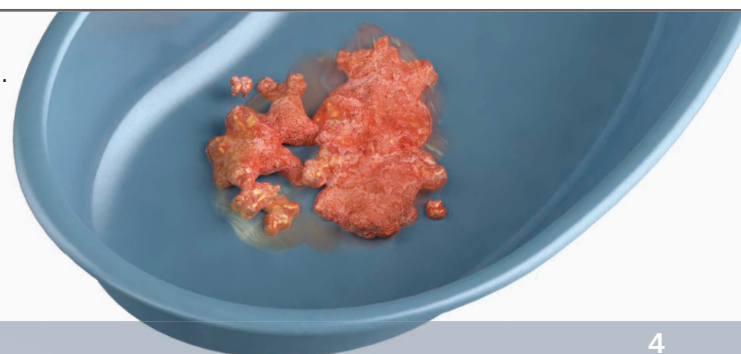

SURGICAL TECHNIQUE GUIDE:

BONE GRAFT HARVESTING

OTHER HARVEST SITES

The design and size options for the Paragon 28® Bone Graft Harvester lends itself to other locations for bone graft harvesting. The same technique can be followed as described above to yield morselized cancellous autograft. Other examples of use are presented below, but are not limited to these options.

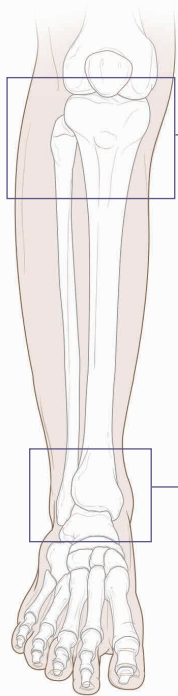

Proximal Tibia

- **Location:**
Lateral to the tibial tuberosity, centered over Gerdy's tubercle
- **Recommended bone graft harvester sizes:**
8 mm, 10 mm
(depending on bone quantity needed)

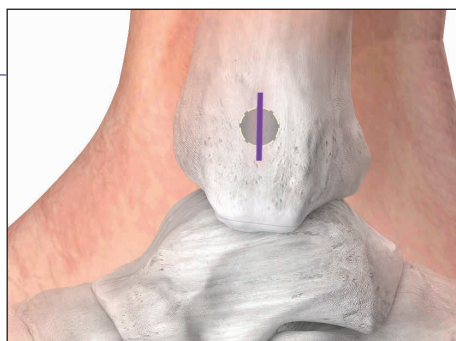

Distal Tibia

- **Location:**
Medial distal tibia, midline over the metaphyseal flare
- **Recommended bone graft harvester sizes:**
6 mm, 8 mm, 10 mm
(depending on bone quantity needed)

CADDY OFFERING

Gorilla® Bone Graft Harvester Caddy

The Gorilla® Bone Graft Harvester Caddy contains the 6 mm, 8 mm and 10 mm single-use Bone Graft Harvester trephines with the corresponding reusable doors, and the 2.3 mm K-wires. This caddy can be provided standalone or can be delivered in the Gorilla® R3CON Plating System Case.

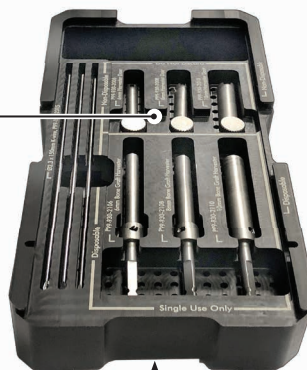

SURGICAL TECHNIQUE GUIDE: INDICATIONS, CONTRAINDICATIONS, AND WARNINGS

Refer to www.paragon28.com/ifus for the complete and most current instructions for use document.

INDICATIONS FOR USE (GORILLA®)

The bone plates and bone screws of the Baby Gorilla®/Gorilla® Plating System are indicated for use in stabilization and fixation of fractures or osteotomies; intra and extra articular fractures, joint depression, and multi-fragmentary fractures; revision procedures, joint fusion and reconstruction of small bones of the toes, feet and ankles including the distal tibia, distal fibula, talus, and calcaneus. The system can be used in both adult and pediatric patients.

In addition, the non-locking, titanium alloy (Ti6Al4V ELI) screws and washers are indicated for use in bone reconstruction, osteotomy, arthrodesis, joint fusion, fracture repair and fracture fixation of the foot and ankle, including the tibia, fibula, tarsus, metatarsals, and phalanges, appropriate for the size of the device.

CONTRAINDICATIONS

Use of the Baby Gorilla®/Gorilla® Plating System is contraindicated in cases of inflammation, cases of active or suspected sepsis / infection and osteomyelitis; or in patients with certain metabolic diseases.

All applications that are not defined by the indications are contraindicated. In addition, surgical success can be adversely affected by:

- Acute or chronic infections, local or systemic
- Vascular, muscular or neurological pathologies that compromise the concerned extremity
- All concomitant pathologies that could affect the function of the implant
- Osteopathies with reduced bone substance that could affect the function of the implant
- Any mental or neuromuscular disorder that could result in an unacceptable risk of failure at the time of fixation or complications in post-operative treatment
- Known or suspected sensitivity to metal
- Corpulence; an overweight or corpulent patient can strain the implant to such a degree that stabilization or implant failure can occur
- Whenever the use of the implant comes into conflict with the anatomical structures of physiological status

Other medical or surgical pre-conditions that could compromise the potentially beneficial procedure, such as:

- The presence of tumors
- Congenital abnormalities
- Immunosuppressive pathologies
- Increased sedimentation rates that cannot be explained by other pathologies
- Increased leukocyte (WBC) count
- Pronounced left shift in the differential leukocyte count

POTENTIAL COMPLICATIONS AND ADVERSE REACTIONS

In any surgical procedure, the potential for complications and adverse reactions exist. The risks and complications with these implants include:

- Loosening, deformation or fracture of the implant
- Acute post-operative wound infections and late infections with possible sepsis
- Migration, subluxation of the implant with resulting reduction in range of movement
- Fractures resulting from unilateral joint loading
- Thrombosis and embolism
- Wound hematoma and delayed wound healing
- Temporary and protracted functional neurological perturbation
- Tissue reactions as the result of allergy or foreign body reaction to dislodged particles
- Corrosion with localized tissue reaction and pain
- Pain, a feeling of malaise or abnormal sensations due to the implant used
- Bone loss due to stress shielding

All possible complications listed here are not typical of Paragon 28®, Inc. products but are in principle observed with any implant. Promptly inform Paragon 28®, Inc. as soon as complications occur in connection with the implants or surgical instruments used. In the event of premature failure of an implant in which a causal relationship with its geometry, surface quality or mechanical stability is suspected, please provide Paragon 28®, Inc. with the explant(s) in a cleaned, disinfected and sterile condition. Paragon 28®, Inc. cannot accept any other returns of used implants. The surgeon is held liable for complications associated with inadequate asepsis, inadequate preparation of the osseous implant bed in the case of implants, incorrect indication or surgical technique or incorrect patient information and consequent incorrect patient behavior.

WARNINGS AND PRECAUTIONS

- Re-operation to remove or replace implants may be required at any time due to medical reasons or device failure. If corrective action is not taken, complications may occur.
- Use of an undersized plate or screw in areas of high functional stresses may lead to implant fracture and failure.
- Plates and screws, wires, or other appliances of dissimilar metals should not be used together in or near the implant site.
- The implants and guide wires are intended for single use only.
- Instruments, guide wires and screws are to be treated as sharps.
- Patient risk as a result of the Baby Gorilla®/Gorilla® Plating System in the MR environment has been minimized.
- Do not use other manufacturer's instruments or implants in conjunction with the Baby Gorilla®/Gorilla® Plating System.
- Do not implant the instruments.

MR SAFETY INFORMATION

The Baby Gorilla®/Gorilla® Plating System has been evaluated for safety and compatibility in the MR environment. It has not been tested for heating, migration or image artifact in the MR environment. The safety of the Baby Gorilla®/Gorilla® Plating System in the MR environment is unknown. Scanning a patient who has this device may result in patient injury.

BONE GRAFT™

HARVEST SYSTEM



PATENTED, DESIGNED & EXCLUSIVELY DISTRIBUTED BY

Exclusively foot & ankle **28**
Paragon®

www.paragon28.com

For Instructions for Use, please visit:

www.paragon28.com/ifus

P99-STG-1001 RevC

™Trademarks and ®Registered Marks of Paragon 28®, Inc.

© Copyright 2020 Paragon 28®, Inc. All rights reserved.

Patents: www.paragon28.com/patents

Paragon 28, Inc. 
14445 Grasslands Dr.
Englewood, CO 80112
(855) 786-2828



Paragon 28 Medical Devices Trading Limited
First Floor Block 7 Beckett Way
Park West Business Park
Dublin 12
D12 X884
Ireland
+353 (0) 1588 0350

DISCLAIMER

The purpose of the Bone Graft Harvester Surgical Technique Guide is to demonstrate the optionality and functionality of the Bone Graft Harvester System instrumentation. Although various methods can be employed for these procedures, the procedure demonstrated was chosen for simplicity of explanation and demonstration of the unique features of our device. Federal law (U.S.A.) restricts this device to sale and use by, or on order of, a physician.